



Another EMC resource  
from EMC Standards

# EMC, systems & installations, 2000, Part 5 - Lightning protection

*Helping you solve your EMC problems*

# EMC for Systems and Installations

## Part 5 – Lightning and surge protection

As published in the EMC Compliance Journal in 2000, [www.compliance-club.com](http://www.compliance-club.com)

Eur Ing Keith Armstrong CEng MIET MIEEE ACGI BSc(hons)  
Partner, Cherry Clough Consultants, [www.cherryclough.com](http://www.cherryclough.com), Associate of EMC-UK  
Phone & fax: (+44)(0)1785 660247, Email: [keith.armstrong@cherryclough.com](mailto:keith.armstrong@cherryclough.com)

This is the fifth of six bi-monthly articles on EMC techniques for system integrators and installers, which will also interest designers of electronic units and equipment. The material in this series is based on the new book “EMC for Systems and Installations”[1], which I co-wrote with Tim Williams of Elmac Services. These six articles contain much less than the book, for example this one contains less than one-third of the material in its chapter 9. This series addresses the practical issues of controlling interference and improving reliability, which would be commercially necessary even if the EMC Directive did not exist. EMC management, testing, legal issues (e.g. compliance with the EMC Directive), and theoretical background are not covered – although they are in [1]. For more information, read the references at the end.

The topics covered in these six articles are:

- 0) General Introduction – the commercial need for EMC in systems and installations
- 1) Earth? what earth? (The relevance of what is usually called ‘earth’ or ‘ground’ to EMC)
- 2) EMC techniques for installations
- 3) EMC techniques for the assembly of control panels and the like
- 4) Filtering and shielding in installations
- 5) Lightning and surge protection**
- 6) CE plus CE ≠ CE! What to do instead

These EMC techniques apply to the majority of land-based systems and installations, and will be relevant for many others. However, some special systems and installations may use different or additional techniques, as mentioned early in the first article in this series. Some of the techniques in this series may contradict established or traditional practices, but they are all well-proven and internationally standardised best practice at the time of writing, and professional engineers have an explicit duty (professional, ethical, and legal) to always apply the best knowledge and practices.

*Remember that safety should never be compromised by any EMC technique.* Where errors or malfunctions in electronic circuits or software could *possibly* have safety implications this is known as functional safety. In such instances meeting the EMC Directive and its harmonised EMC standards will probably not be enough to meet safety laws. For more on this read the IEE’s professional guidance document “EMC and Functional Safety” [2].

### Table of contents for Part 5

5.1	The economics of EMC and lightning	2
5.2	How lightning disturbances can affect electronics	2
5.3	Overview of a basic lightning protection system (LPS)	2
5.3.1	The basic construction of an LPS	3
5.3.2	Preventing side-flashes	4
5.3.3	Bonding external cables and metallic services to the LPS	5
5.3.4	How much lightning current flows in external cables?	5
5.4	Additional measures to protect electronic equipment	6
5.4.1	Enhancing the LPS structure	6
5.4.2	Improvements within a structure	8
5.4.3	Zoning, and surge protection device ratings	9
5.4.4	Choice and installation of SPDs	10
5.5	Protecting from non-lightning surges	13
5.5.1	Nuclear electromagnetic pulse (NEMP) and EMP	13
5.5.2	Other external and internal surges	13
5.6	References and further reading	14

## 5.1 The economics of EMC and lightning

Most lightning standards, such as IEC 61024-1 [3] and the main body of BS 6651:1991 [4], are concerned with personnel safety and preventing structural damage, and do not provide adequate protection for electronic equipment. The protection of the electronics in a structure is an increasing concern because use of electronics, especially in critical areas, is increasing very rapidly. Also, modern electronics depends upon ever-decreasing feature sizes and operating voltages in silicon ‘chips’, which makes them more vulnerable to surges.

The economic losses due to lightning damage to electronics have been estimated for the US economy at several thousands of millions of \$ per year. [5] quotes a survey which claims the losses due to computer downtime varies from around US\$6 million/hr for a retail brokerage, US\$3 million/hr for a credit card authorisation service, to around US\$15,000/hr for ATM services.

Losses in process and manufacturing industries due to electronic failures can also be very high, and £250,000 per day is not unknown in the UK. In continuous processes even a small ‘glitch’ can cause huge financial losses. In the entertainment industries a brief failure can ruin an entire ‘take’ or show, particularly expensive during live events which cannot be repeated. Read about the consequences of the electrical storm that struck a Texaco Refinery and significantly affected the UK’s GNP for that year in [6] and [7] and [25]. Most engineers try to keep costs down, but the cost of making every electronic installation that you are involved with lightning-proof can cost very much less than a single such incident.

## 5.2 How lightning disturbances can affect electronics

A typical lightning ‘strike’ can last for over one second and consist of many ‘strokes’ (discharges), sometimes over ten, each with an ‘arc-channel’ current of between 2kA and 200kA (1% of strokes exceed 200kA).

- **Earth lift.** Soil has significant resistance, so lightning strikes can cause large potential differences between areas nominally at the same ‘earth’ potential. [8] shows that the ‘traditional’ practices (which are not recommended in this series) of star earthing and bonding cable screens at only one end makes this sort of damage more likely.
- **Magnetic induction.** Very high surge voltages can be induced into any conductors by magnetic coupling from lightning strikes up to 100 metres away.
- **Current injection.** Direct strikes to external equipment or cables often results in damage to the internal equipment they are connected to, and can damage unrelated equipment due to side-flashes in shared cable routes or terminal cabinets.
- **Electric induction.** Electric fields of up to 500kV/m can occur before a lightning strike, over an area of up to 100m from the eventual strike point. These can induce damaging currents into conductors and devices.
- **Lightning Electromagnetic Pulse (LEMP).** This ‘far-field’ effect can be caused by cloud-to-cloud lightning as well as by distant cloud-to-ground strokes.
- **Thermal and mechanical effects** (e.g. shock waves in the air) due to the intense energies associated with lightning. Mostly affects a structure’s fabric and its lightning conductors.
- **Multiplicity and duration of strokes in a single strike.** This is important for error-correction and system software recovery.

This article focuses on the type of lightning protection systems (LPSs) described by [3] and [4], which intercept the strikes and route them to earth. In so doing they create locally intense electromagnetic disturbances which can damage electronic equipment and/or corrupt data unless the techniques described here are used, although of course these local disturbances are much less damaging than having no LPS at all.

A number of people are proposing a different lightning protection technique, sometimes called ‘point discharge’ which aims to neutralise the electric fields and prevent lightning strikes from happening in the first place. If this works as claimed it would clearly be of great benefit for protecting electronics. An example of an article commending this new technique is in [9]. If you plan to use any novel lightning protection techniques on your next project it would be a good idea to check that it won’t suffer from excessive buildings insurance policy rates.

## 5.3 Overview of a basic lightning protection system (LPS)

First we’ll take a brief look at basic LPSs to protect people and the structure in typical commercial or industrial buildings, based on [4] (the UK’s code of practice for lightning protection), and then we’ll see how to enhance

them to protect electronics. LPS design should always be done by an experienced, competent professional who involves all interested parties before, during, and after all stages of design, including: architects; utilities (gas, water, power, telephone, etc.); the owner's Fire and Safety Officers; TV radio security and telecommunications system installers; and the builders.

A typical LPS intended just for personnel safety, and protection of the structure, typically requires:

- A risk assessment based on actual lightning exposure
- Design of the air termination network and down-conductors
- Design of the earth termination network and earth electrodes
- Bonding of the metalwork within a structure, and of the metallic services entering a structure, to the LPS.

Special structures may require special LPS measures.

Risk assessment is based on lightning strike density maps called isokeraunic (or isoceraunic) maps, plus:

- The structure's 'effective collection area' for lightning strikes.
- Its use.
- Its type of construction.
- Its contents.
- The consequential effects of any damage.
- The degree of its isolation from other structures.
- The type of terrain.

All of these are easily found using [4], and determine whether an LPS is considered essential or not. Lightning standards also provide guidance on the anticipated characteristics of lightning strikes (e.g. the maximum stroke current: much higher in the tropics than in the UK).

### 5.3.1 The basic construction of an LPS

A basic LPS consists of an air termination network, a down-conductor network, and an earth-termination network, as shown in Figure 5A. The air termination network intercepts the actual lightning strike and diverts it via the down-conductors to the earth termination network, thereby protecting the structure. Single conductor

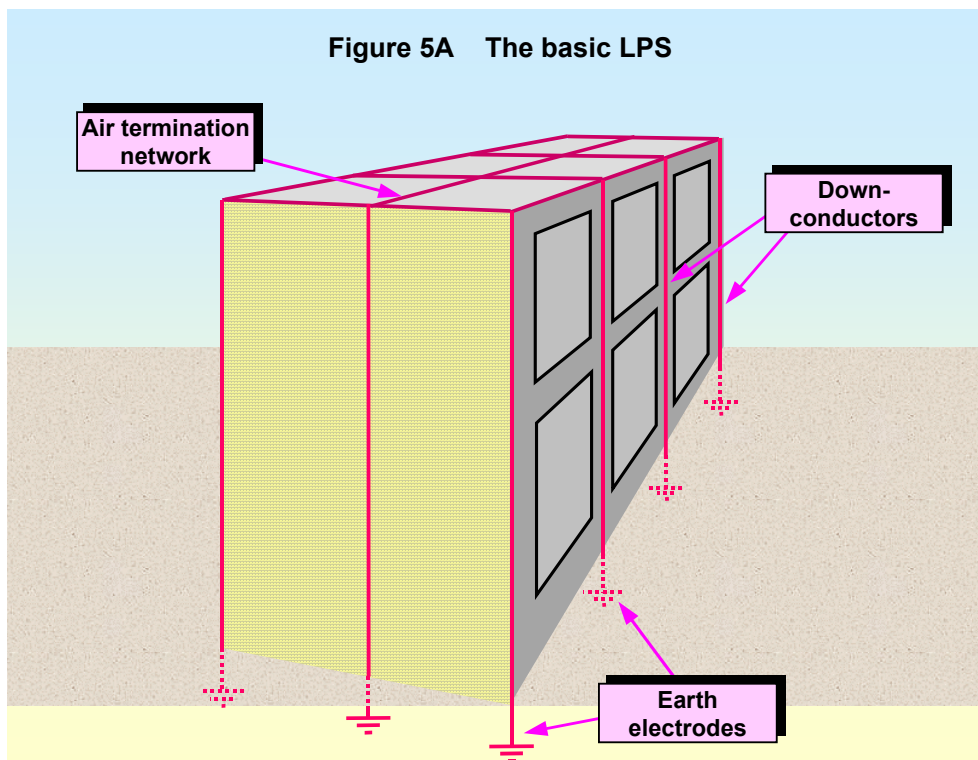

LPSs are not recommended any more – they tend to flash-over to the rest of the structure, and their strong voltage gradients at ground level can cause safety hazards.

An LPS must withstand extremes of weather, electrical, electromagnetic, and mechanical stresses, and last many years, and only certain metals and combinations of metals are suitable. Metal parts of the structure

(‘natural’ components, including re-bars) can often be used as parts of the LPS, or even as the whole LPS, providing they meet specified requirements. Copper theft from external LPSs is a serious concern, so the use of ‘natural’ components is often preferred.

The air termination network can be a mesh of conductors on roofs and the outsides of walls. Different types of air terminations create differently-shaped ‘zones of protection’ to protect exposed equipment such as antennae, radar and satellite dishes, security cameras, air-conditioning plant, water tanks, etc. from direct strikes. A closer mesh is needed for more vulnerable structures, such as fuel or explosives stores (we shall see later that the same helps to protect electronics). An all-metal all-welded structure provides the perfect air-termination network, and of course is ideal for electronic protection too.

There should be several down-conductors equi-spaced around the structure, to share the lightning current from the air termination network. They should be straight and vertical to provide the most direct route to the earth electrodes, with special rules for when they can’t be.

The earth termination network is the system of earth electrodes which dissipates the lightning currents into the mass of the soil and/or rock beneath the structure to be protected. All soils and rocks have finite conductivity, and [4] describes what should be done in the design, construction and maintenance of earth electrodes to achieve an overall earth resistance of  $10\Omega$ . Higher (or lower) resistances may be allowed (or needed) in special cases.

An LPS with an overall earth resistance of  $10\Omega$  and a (not excessive) lightning current of 100kA can cause an ‘earth lift’ for the structure of 1MV. Clearly it is important to have a good CBN within a structure, and to design the earth electrodes to control the voltage gradient around it to keep the ‘step voltage’ during a lightning strike within acceptable levels. It is no good putting up signs warning people in or near a building to take very small steps during thunderstorms!

Typical earth electrodes include rod electrodes at the foot of each down-conductor a metre or so from the structure’s boundary, driven vertically into the soil. Reinforcement in concrete foundations (especially pilings) can achieve a very low earth resistance, and is called a foundation earth electrode. Lengths of conductor run under the soil are strip electrodes, but when used to reduce voltage gradients they may be called potential grading electrodes. A foundation strip electrode is a strip electrode laid in the trench cut for the foundations of a structure, before they are laid or poured. A ring earth electrode follows the perimeter of a structure at a given distance, bonding all the other electrodes and forming an unbroken ring (like the internal bonding ring conductors (BRCs) described in Part 2 of this series [10]).

### 5.3.2 Preventing side-flashes

During a lightning strike the high rate of change of current in down-conductors (up to 100 kA/m.μs for a conductor carrying 50% of the strike current) can give rise to very high voltages from top to bottom, due to the inevitable inductance of the conductors, possibly as much as 100kV/metre of height. These can ‘side-flash’ to other metalwork, even right through the fabric of the structure (bricks, concrete, windows, etc.) often causing cosmetic or structural damage and frightening those personnel that aren’t injured. Prevention of side-flashing uses three techniques, given here in order of preference:

- Increasing the number of down-conductors and reducing the mesh size of the LPS, to reduce inductance and reduce the potential differences.
- Bonding the LPS to any metalwork or conductors it might side-flash to (both external and internal).
- Isolation by achieving large clearance distances between the LPS and the things it might side-flash to (may need >2 metres in air).

Bonding the LPS to internal metalwork usually means bonding to the CBN (as shown in Figure 2D of Part 2 of this series [10]). Although this allows lightning currents to flow internally, it is not a problem for a structure that has a well-meshed CBN because the lightning currents tend to concentrate in conductors at the outer edges of a structure. The unwanted currents that do flow are a small price to pay for freedom from side-flashes [11].

### 5.3.3 Bonding external cables and metallic services to the LPS

All metal entering or leaving a structure – whether cable sheathing, screening or armouring, or piping for electric power, gas, water, rain, steam, compressed air, dry risers, or any other service – should ideally be bonded directly to the main earthing terminal (MET), as near to the point at which the service enters or leaves the structure as possible. So planning and design should aim to bring all services and external cables in at a single area, preferably within 2 metres of the MET.

Power and signal conductors, and any other metal items that can't be bonded to earth, should have surge protection devices (SPDs) connected to the MET. Figure 5B shows general bonding principles, and is based on a figure in [4].

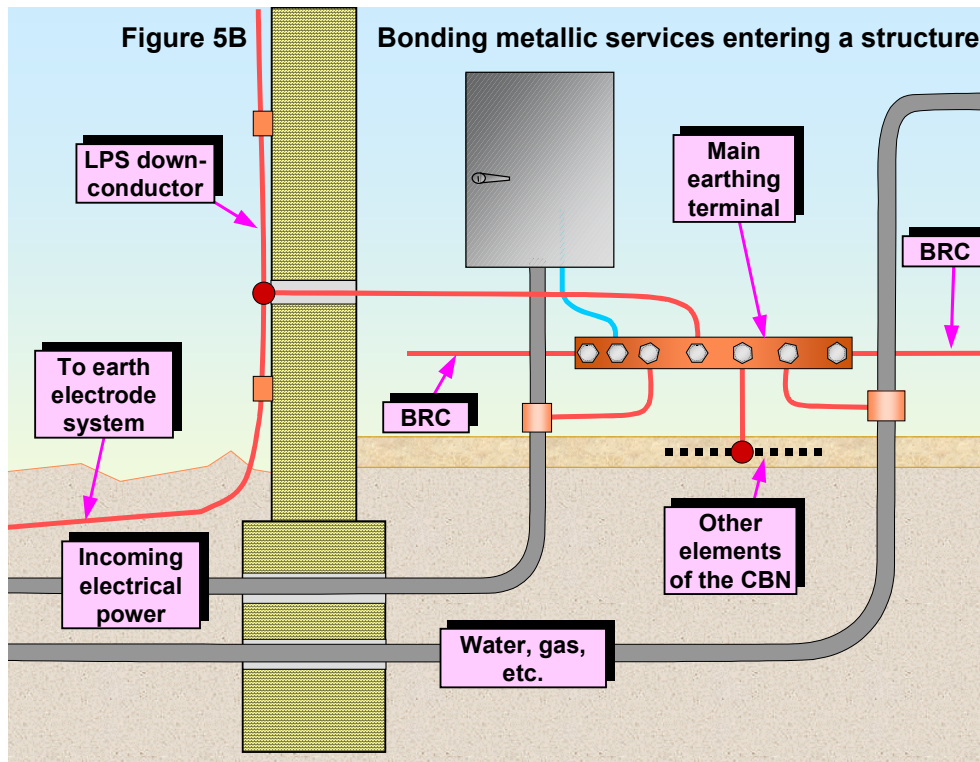

All metallic cables and services should ideally have travelled underground for their entire length. Overhead cables and services are very exposed and there are special rules for dealing with these. Even telephone wires should also enter underground where possible, but most lightning standards dodge the issue by stating that their safety is the responsibility of the appropriate Telephone Utility.

### 5.3.4 How much lightning current flows in external cables?

Some lightning current will flow in the external cables and metallic services bonded to the LPS, and a rule of thumb is that their levels depend on their resistances – compared with the earth electrode system's resistance. [4] provides (statistical) figures for the lightning currents to be expected, so once the various resistances are known (calculation or measurement) a simple calculation based upon parallel resistors will indicate how the lightning current will divide up.

A more accurate division of currents would require knowledge of the surge impedance of the alternative paths that the lightning current could take (including the surge impedance of the earth electrode system), for the surge waveforms (hence frequency spectra) associated with the types of surges to be controlled. It is possible to calculate the division of currents using field-solving simulation software (given sufficient knowledge of the structure, electrodes, soil, cables, etc.), or based on site measurements of surge impedances using appropriate instrumentation. However, since most of the total energy in a lightning surge is contained within the frequency range below 10kHz, and since most underground structures and cables will probably be predominantly resistive up to at least 10kHz, to control the heating effects of lightning surges it is probably sufficient to consider resistive current-division only and allow a suitable 'engineering margin'.

Where an individual evaluation isn't done, [12] suggests that 50% of the total lightning current in the LPS may be assumed to enter its earth termination network – the rest being distributed equally among the metallic cables and services entering or leaving the structure. Screened or armoured cables may be assumed to carry all of their

portion of the current in their screen or armour. Unscreened and unarmoured conductors may be assumed to distribute their portion of the lightning current equally among their conductors. Telephone cables that enter the structure above ground level may be assumed to carry currents of up to 5% of the main lightning arc channel current. An appendix in [3] shows how to calculate the surge current handling capacity of a cable, screen, or armour.

## 5.4 Additional measures to protect electronic equipment

Appendix C of [4] addresses the protection of electronics, as does IEC 61312-1, IEC 60364-4-443, IEEE C62.41, and IEEE C62.64. The common techniques in these standards are introduced below, assuming that a basic LPS already exists. It turns out that all of the good EMC practices described in the earlier parts of this series are of great value in helping to protect electronics and data from the effects of lightning and other types of surges, for example:

- Segregation of equipment and their cables into areas or zones (where their surge withstand ability can be matched to the protection provided).
- Improving the structure's CBN into a three-dimensional MESH-BN or a number of MESH-IBNs.
- 360° bonding of cables' screens to their local RF references, at both ends (see section 3.6).
- Running all cables close to PECs which are bonded to the CBN at both ends.
- Use of metal-free fibre-optics and other galvanically isolating non-metallic data and signal communications.
- Segregating cables into classes and maintaining spacings between classes, whilst routing cables along common routes over PECs to minimise inductive loops.
- Filtering and shielding equipment (or zones of equipment) within a structure.

We need an idea of how much effort to expend, so should answer the following for each function of each item of equipment:

- Is catastrophic failure requiring replacement of the equipment acceptable?
- Is the equipment merely required to survive a lightning event undamaged?
- Must the function continue to be available, although with reduced performance (and to what degree), during a lightning event?
- Is the function safety-critical (or mission-critical), i.e. it must continue to be available with full specification during a lightning event?

Co-ordination is required between the equipment's criticality, its ability to withstand lightning threats, and the lightning threats that the installation and its location exposes the equipment to. Appendix C of [4] describes how to calculate lightning exposure and risk for the electronic equipment in a structure (this is a more suitable method than the risk assessment given the main body of [4]).

### 5.4.1 Enhancing the LPS structure

Appendix C of [4], [12], [13], and [14] all recommend increasing the number of down-conductors to reduce inductance and share currents more. Each down-conductor will carry less current and create lower magnetic fields inside the structure. Reinforced concrete structures that use welded or tied re-bars (with the re-bars also welded to metal window or door frames) can create a very well protected structure. Ring earth electrodes or foundation strip electrodes are also often recommended.

Calculating how far to go with LPS enhancements is difficult for all but the simplest structures, and [14] describes a systematic approach. LPS simulation software is understood to be commercially available, but some universities and consulting companies specialising in lightning issues have more powerful simulation software and may run LPS design simulations for a fee.

A completely enclosed metal structure (welded at all seams) would make a very good LPS – a 'Faraday cage' with the low internal fields during a direct lightning strike. Where electronics absolutely must survive lightning or similar external surges, or continue to perform without degraded performance, such a structure may be required. In some cases a 'double box' type of Faraday cage may be required – the sort of construction that is found on high-specification shielded rooms for EMC testing.

Power or metallic signal cables passing between two structures can inject very severe surges, due to the huge potential differences that can exist between two structures when one of them is struck by lightning. They can also inject non-lightning surges caused by earth faults. To help protect the cables themselves, as well as the electronics in the structures they interconnect, [4] and [12] recommend that the earthing systems of the structures should be interconnected by many parallel metallic paths, preferably forming a mesh. The metal conduits, ducts, trunking, armour, etc. associated with the cables, and any metalwork or metal services (gas, water, etc.) passing between the two structures should be bonded to the interconnecting bonding mesh and the METs at each end.

Bonding of external metallic cables (power, telephone, data, etc.) and services using metallic ducts or pipes (water, gas, steam, etc.) should be improved by bringing them all into (or out of) the structure in one small *underground* area no more than 2 metres from the neutral of the main incoming supply disconnector. There they should be bonded to a single large equipotential bonding plate, which is similar in concept to the filter bonding plate shown in Figure 4E of Part 4 of this series [15]. The idea is to create a ‘star point’ between the structure to be protected and the rest of the world, to help prevent external surges from travelling *through* the structure. Where anything metallic cannot be bonded directly to the equipotential bonding plate, it should be connected via an SPD installed on the equipotential bonding plate.

The equipotential bonding plate should be inserted into the line of the external ring earth electrode and bonded to it at both ends. It should also have additional multiple connections to the internal bonding ring conductor (BRC) of the structure (refer to section 2.4 of [10]) and to concrete reinforcing or foundation electrodes, as shown by Figure 5C. Foundation strip electrodes or foundation earth electrodes may be used instead of a ring earth electrode.

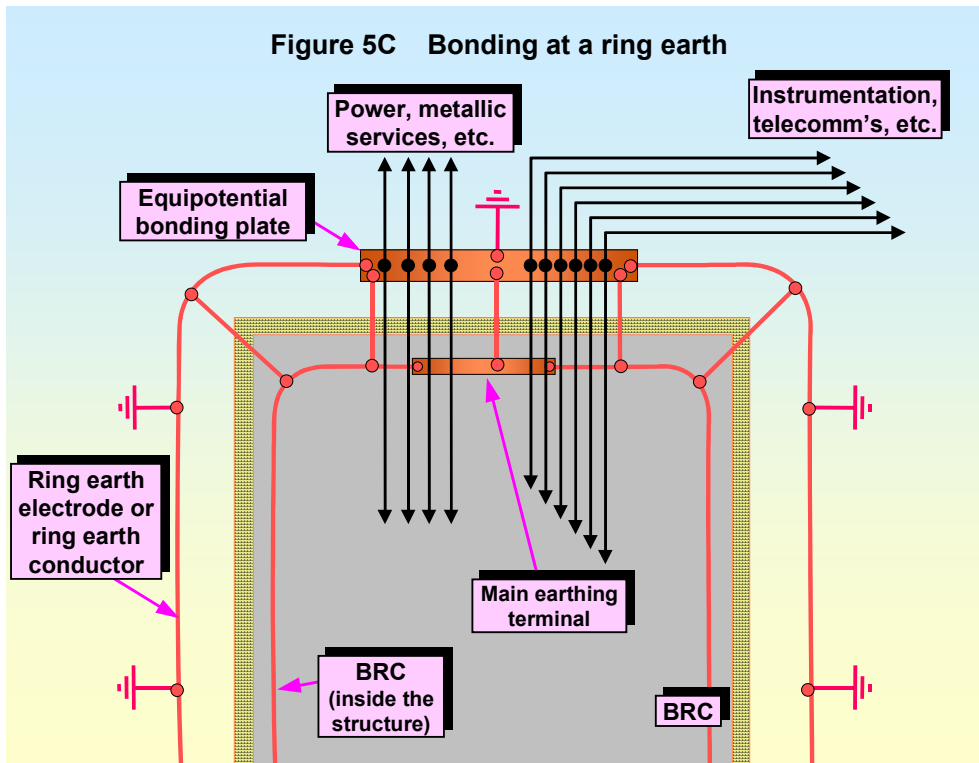

A reinforced concrete structure could interconnect all its vertical and horizontal re-bars and use them as the “natural components” of a very effective LPS. The re-bars could be all that is needed for the down-conductors and foundation earth electrode. The equipotential bonding plate for the “star point” of such a structure could be set into the wall re-bars as sketched by Figure 5D. This construction approaches the ideal of a welded all-metal construction for lightning protection, because the aperture dimensions of the mesh formed by the re-bars is negligible for the frequencies associated with lightning disturbances (see Section 4.5 of [15]).

Where rod (or radial strip) electrodes are used, one rod (or a number of strips) should be near to the equipotential bonding plate and bonded directly to it.

When protecting the electronics in older structures it may not be practical to re-route all the incoming/outgoing cables and services so they all enter/exit in one small underground area. Various techniques are suggested in [1], often involving the use of additional equipotential bonding plates and two or more ring conductors.



Water, sewage, and similar services in plastic piping can be surprisingly conductive, and the insertion (with the Utility's permission) of a length of metal pipe (say a metre or two) where they cross the boundary of the structure should be considered. These should be bonded to an equipotential bonding plate.

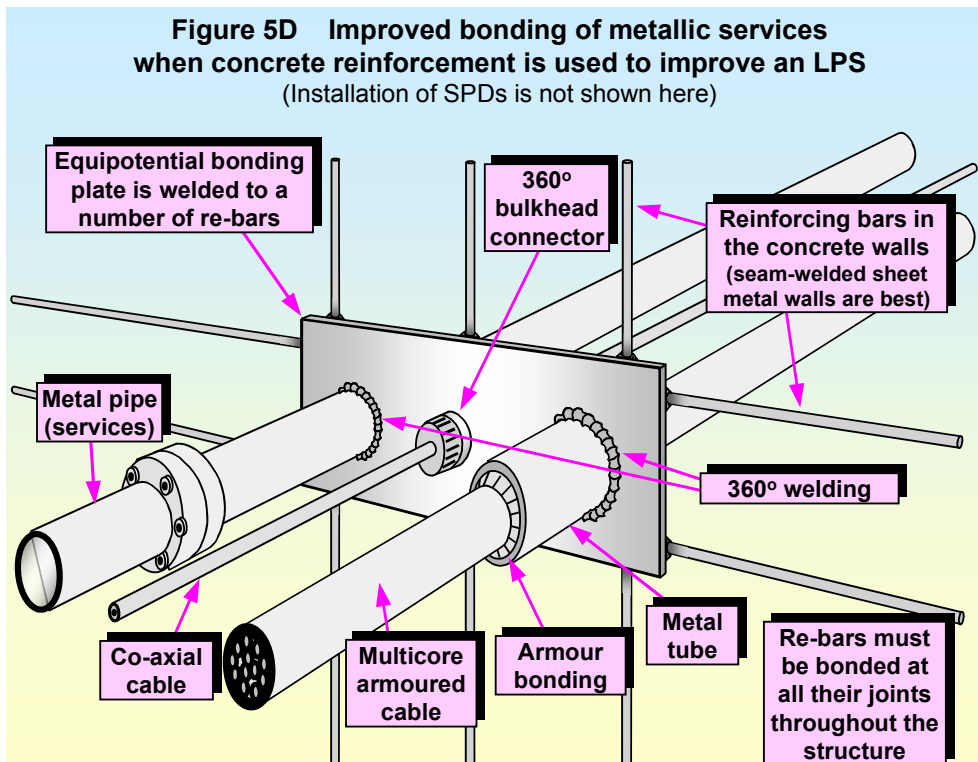

#### 5.4.2 Improvements within a structure

The CBN and cable routing within a structure as described by [10] are also important for protecting equipment from the effects of lightning.

As well as preventing ‘earth lift’ within a building, a MESH-CBN with 3 to 4 metre spacings (or less) provides useful shielding against lightning induction (magnetic and electric), with their vertical components giving the greatest protection from the magnetic effects of ground strikes. Where the mesh size has to be larger (e.g. loading bays, display windows, etc.) sensitive electronic equipment should not be installed near that area unless it has been “hardened” to withstand the likely effects of lightning.

Cables should not be run near to lightning conductors, especially in vertical runs. If this is not possible, sturdy braid screens, armour, or enclosed conduit should be used, always bonded at both ends to the CBN so they act as a parallel earth conductor (PEC) with a frequency response good to 1MHz or more [10]. Unprotected conductors must always be kept well away from parts of the LPS, 2 metres or more.

Always route cables along parts of the CBN, using them as a PEC, but avoid running cables near the top and outsides of a structure because lightning currents tend to concentrate in them. The more highly meshed a CBN is, the more the lightning currents will avoid flowing inside a structure, freeing up more cable routes. But cables run in completely enclosed metal ducts or conduits which are continuously conductive, have good high-frequency bonds at joints (see figures 2F and 2G of [10]), and are bonded to the CBN at both ends, can usually be routed anywhere without problems [13].

Appendix C of [4] gives example calculations for the induced voltages in various types of signal cable due to lightning events and shows how they are reduced appreciably by bonding their cable screens, armour, or trays to earth at both ends to make a PEC. Where direct bonding of cable screens at both ends is not permitted (for a good engineering reason, not merely a mistaken desire to avoid ‘ground loops’), SPDs should be fitted instead to the local earth bonding plate as specified by ECMA 97 for certain types of LAN.

Of course, bonding cable screens at both ends runs the risk of overheating the screen with earth-loop or surge currents. Most earth-loop currents are at power frequency and the solution is to run the whole length of the cable close to a low resistance PEC, as described in section 2.5 of [10]. Annex D of [12] gives a useful formula for calculating the minimum cross-sectional area (csa) for cable screens so they will withstand lightning surge currents. All cables between items of equipment should follow the same route (while maintaining adequate

separation by distance or screening, as described in section 2.8 of [10]) to minimise the size of any loops and reduce induced surge currents.

Electrical conductors are a liability for EMC and lightning protection, so metal-free fibre-optics, wireless, microwave, laser, or infra-red communications are always preferred. However, the electronic devices at the ends of such links are sensitive and must be well protected. When using such techniques to interconnect two structures [4] recommends that they should be rated for >100kV galvanic isolation, although very simple arithmetic based on peak arc-channel current of 20kA and an earth resistance of 10Ω suggest that 2MV might be more appropriate. Inside a structure a combination of mesh-bonded CBN and SPDs can reduce surge voltages to as low as is required to enable PCB-mounted opto-couplers to be used for galvanic isolation without fear of damage or side-flashing.

The central volume of a lightning-protected structure is the one usually least exposed to the effects of lightning, so this is the best place to install the most sensitive equipment. Places to avoid when installing equipment include roofs; top floors (especially of tall structures); and near to outside walls, outside corners, down-conductors, or tall structures such as masts, chimneys, etc. Of course this depends on the quality of the LPS, and in all-welded all-metal structures location of equipment is not generally of any concern.

### 5.4.3 Zoning, and surge protection device ratings

So far this article has only mentioned surge protection devices (SPDs) in passing, which may surprise some readers. But SPDs on their own cannot protect from the effects of lightning – correct design and construction of LPSs and CBNs, and careful location of equipment and routing of their cables, is also required. In fact, without a well-meshed CBN and the other techniques described above, it can be very difficult and expensive to use SPDs effectively. For example, a typical SPD fitted to a data cable inside a building will not protect against a side-flash from a down-conductor, and may not even be sturdy enough to protect against magnetic induction from a nearby down-conductor.

SPDs should not be fitted where there is a risk of fire or explosion, unless special precautions are taken (these techniques are outside the scope of this series).

Zoning within a structure was described in some detail in [15] (see its Figure 4A). It is also a powerful technique for protecting equipment from lightning disturbances because it allows us to define zones of different over-voltage exposure, and so co-ordinate their protection.

Methods of co-ordinating protective zones and equipment have been used for many years by the telecommunications industry [16]. But in general it has been difficult because few EMC directive immunity standards include surge testing. However, from 1<sup>st</sup> July 2001 almost all newly supplied commercial and light industrial equipment in the EU will have to be declared to meet new EMC standards that include surge tests. These use a standardised lightning waveform, with typical peak levels of 2kV from each line to ground and 1kV from each line to each other line, for AC power. Where cables can be longer than 30 metres they may also require surge tests with respect to ground, typically 1kV peak. Changes to the generic immunity standard for industrial equipment will require products supplied after 1<sup>st</sup> April 2002 to meet similar surge levels.

It has been found that over-voltages due to lightning surges in AC power distribution networks become attenuated as they progress through the wiring in a structure. Appendix C of [4] and IEEE C62.41-1991 [17] both identify three distinct zones with differing over-voltage exposure categories:

- Category C:** Most severe. Power conductors outside a structure; supply side of main incoming LV distribution board/switchgear; load side of distribution board/switchgear for outgoing mains cables such as to another structure or external equipment such as transformers, pumps, external lights, etc.
- Category B:** Power conductors inside a structure: between load side of incoming distribution board and supply side of socket outlet or fused spur, or within equipment not fed from a wall socket, or sub-distribution boards located within 20 metres cable run of Category C, or plug-in equipment or fused spur within 20m cable run of Category C.
- Category A:** Least severe. Power conductors to plug-in equipment or fused spur located more than 20 metres cable run from Category C and/or 10 metres from Category B. (Category A may not exist in smaller structures.)

All data/signal cables (e.g. telephone wires) entering a structure from outside are considered to be in Category C up to the point where they are fitted with SPDs. Surges in telco lines tend to spread the surge energy over a

longer time period, rather than it becoming attenuated as happens in power distribution networks, so SPDs for telecomms' lines are usually tested with a different surge waveshape to those for use on AC power.

Appendix C of [4] employs a risk assessment method which determines whether the lightning risks to an equipment are high, medium, or low. Then, for each of the above three categories and for each level of risk, it lists the SPD ratings required. These are reproduced in Table 1.

<b>Table 1 Magnitude of surge wave forms for testing mains SPDs</b>		
<b>System exposure</b>	<b>Peak voltage (kV)</b>	<b>Peak current (kA)</b>
<b>Location category A</b>		
Low	2	0.1667
Medium	4	0.3333
High	6	0.5
<b>Location category B</b>		
Low	2	1
Medium	4	2
High	6	3
<b>Location category C</b>		
Low	6	3
Medium	10	5
High	20	10
(Telecommunication lines are Category C, but their SPDs are tested with different wave forms and different peak values)		

Don't forget that the currents in an SPD also flow in its interconnecting cables, terminals, and fuses, which should be dimensioned accordingly.

[12] describes the zoning approach more in favour in Germany, using the protection categories I to IV from [3] and its concept of "Lightning Protection Zones" or LPZs. LPZs are created by the earth-bonding structure and any additional shielding and each have their own perimeter BRC (see Figure 2H of [10] and Figure 4A of [15]). As described in [10] and [15] all the cables, metalwork, and metallic services that cross the perimeter of an LPZ should either be bonded or fitted with SPDs and/or filters to its BRC.

Unlike [4] and [17], [12] does not provide surge voltage/current specifications which are easy to use for ensuring the protection of equipment in a zone. It is up to the lightning expert who is designing the system to determine the ratings from an understanding of the structure and the protection needs of his zones on a case-by-case basis.

Yet a different approach to risk assessment for the lightning protection of equipment, zoning and selection of SPD/equipment surge ratings is used by IEC 60364-4-443:1999 [18]. [18] only recommends peak over-voltage ratings for SPDs and not their peak currents or energies (however, the surge impedance of the mains supply is usually taken to be  $2\Omega$ , so these can be calculated). The zoning and voltage ratings in [18] are the same as those given in IEC 60664-1:1992 [19] and also in table J1 of the product safety standard EN 61010-1:1993 [20].

It is a great pity that there is no coordination between the surge test levels which will be required by new EMC immunity standards from July 2001, the overvoltage protection specifications of [18] and [19], and the exposures predicted by lightning standards such as [4], [12], and [17]. Equipment which meets the EMC directive's new surge immunity standards from July 2001 can't just be used anywhere and be expected to be reliable – it will still need to be evaluated according to its zone or risk category within a given structure, and either moved to a zone with lower exposure or fitted with additional SPDs or other protective measures as required.

#### **5.4.4 Choice and installation of SPDs**

SPDs may be installed at the structure's equipotential bonding plate or MET, at its internal zone boundaries, and sometimes at items of equipment themselves. The peak voltages and currents to be suppressed by SPDs are

discussed above. But co-ordinating an SPD with the equipment it is to protect requires choosing the appropriate type(s) of SPD and installing them so that their peak let-through voltage doesn't exceed what the equipment will stand.

SPDs present a high resistance (and have low leakage current), until the voltage across their terminals exceeds their trigger level. Then their resistance falls sharply and they either clamp their terminal voltage (like a zener diode) or 'crowbar' it by reducing it below the triggering level. There are four basic types of SPD:

- Gas discharge tube (GDT): essentially just a spark gap, slow but very high power.
- Metal-oxide varistor (MOV): a bulk semiconductor, faster but less rugged than a GDT.
- Avalanche: semiconductor devices similar to a zener, very fast indeed but not very high power.
- SCR: semiconductor devices similar to thyristors or triacs, slow but will handle high currents.

Figure 5E indicates the voltage versus time waveforms of these four types of SPD when exposed to the leading edge of a typical surge test waveform.

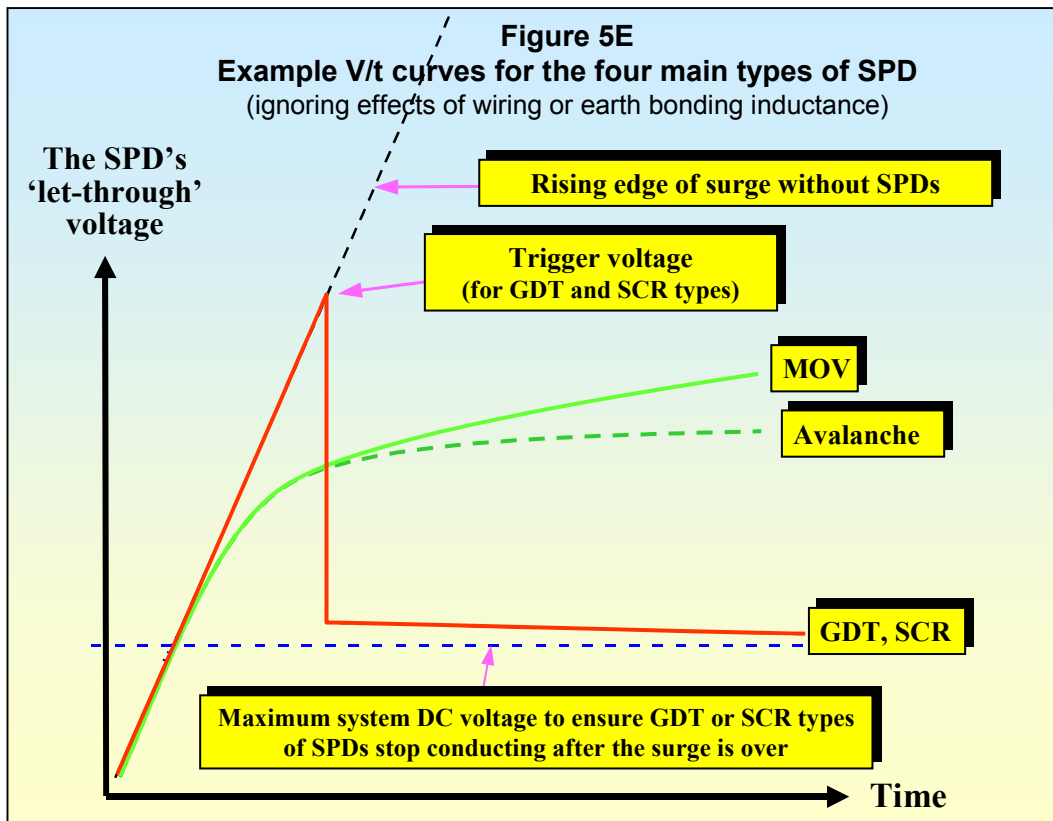

The slow speed of GDT and SCR devices means they can momentarily let-through voltages which could cause damage. Their 'foldback' type of characteristic requires careful design if they are connected to a DC source so that once triggered they do not remain conducting forever. Some surge protection units use a combination of different SPD types to achieve the overall performance desired, but simply paralleling a low-power MOV (for example) with a high-energy GDT can prevent the GDT from triggering, so such units usually incorporate an inductor between the foldback device and the clamping device, with the clamping device on the protected side, as shown in Figure 5F. When their voltage drops are acceptable, resistors may be used instead of inductors (e.g. for telephone cables). MOV types used to be considered unreliable, but those that meet the latest standards appear to be very robust and some very high-energy MOV products are available.

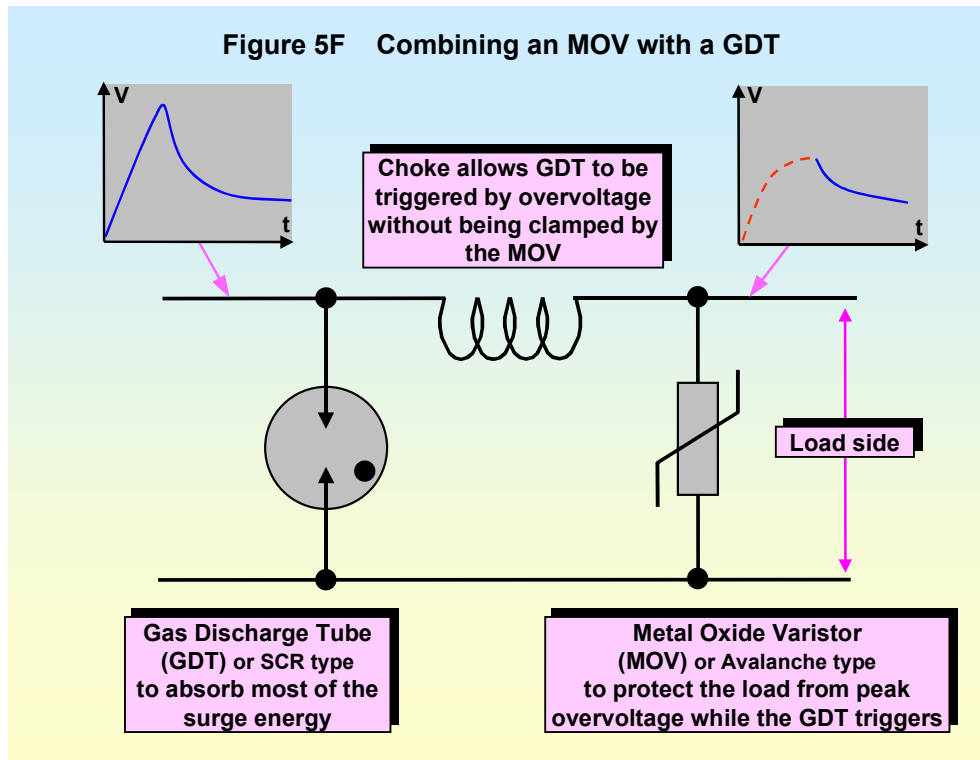

It is very important to rate SPDs for their peak current, voltage, and energy of the surges they are to control, or else their life is likely to be very short. Also, exploding SPDs are very dangerous to personnel, and can create fire hazards. Even when rated correctly all SPDs are prone to failure due to the stressful job they have to do, so wherever SPDs are fitted they should be inspected and checked regularly and replaced if found to be degraded or failed. This is a very onerous job so a number of SPD manufacturers now offer surge protection units fitted with indicators which warn of degraded performance and impending failure, or a failed device.

SPDs for use on AC power are generally provided in a wire-in package style, but this is not appropriate for signals and data lines which use standard connectors, such as RJ11 (e.g. telephones), BNC (e.g. radio antennas), etc. and manufacturers provide ranges of SPDs in packages fitted with such special connectors. All types of SPDs (except GDTs) have quite a high capacitance, which limits their application to low-speed signals and data. High-speed data and RF can use GDTs to remove most of the energy in a surge, leaving their initial let-through to be coped with by the equipment's circuit design. Note that data and signals are lost during SPD activity, so robust error-correcting communications protocols are usually needed.

The actual let-through voltages of the SPDs can bear no relation to their data sheets, if they are not installed correctly. Lead lengths must be short, and earthing must be relative to the protective conductors of what is being protected (a separate 'SPD earth' is a recipe for disaster). For SPDs which are not fitted to actual equipment the LPS or CBN involved must have a low impedance at lightning frequencies (say, up to 1MHz), hence the use of ring electrodes and similar techniques.

The real let-through voltage of an SPD is the sum of its own terminal voltage plus the transient voltage drop in its connecting leads due to their inductance (usually reckoned to be  $1\mu\text{H}/\text{metre}$  for unbound wires). For surges associated with lightning, the overall length of both SPD connections should be under 1 metre. For example: tests reported in [21] showed that on a 6kV 3kA test a particular SPD had a let-through of 630V when it was installed correctly (leads <250mm long and bound together), but with 2 metre long bound leads it let through 1,200V, and with unbound 2 metre leads it let through 2,300V.

None of the three lightning standards [4] [12] or [3] says much about installing SPDs, but a great deal of SPD installation detail is available from references [5], [11], and the Furse electronic systems protection handbook [21]. As well as Furse, most other SPD manufacturers will provide free booklets on how best to install their products.

SPD protection can also be defeated by the 'earth lift' across a structure, but the measures described earlier should deal with this for SPDs located at equipotential bonding plates and METs. But when applying SPDs to items of equipment, SPD surge currents can cause a significant 'earth-lift' at the equipment itself due to the inductance of its protective bonding conductor – unless the equipment's chassis is bonded directly to a MESH-

CBN. When an equipment suffers an earth-lift, all of its signal and data interconnections, and the equipment it is connected to, can be put at risk of over-voltages.

So adding an SPD to the AC power input as a standard precautionary measure may not be a good idea, as it can cause damage to signal and data ports if interconnected equipment is not installed correctly using a MESH-CBN. Where a low-impedance CBN, or the quality of installation cannot be assured, SPDs may therefore be needed at all metallic interconnections – making galvanic isolation techniques such as fibre-optics much more cost-competitive. Equipment earth-lift due to SPDs is explored a little more in section 3.14.7 of [23], and in [8].

All SPDs fail eventually, and since the majority use metal-oxide-varistor types (whose failure mode is to leak increasingly and finally to short-circuit), they need to be fused when used on AC or DC power. The fuse must be rated to withstand the current surges from large numbers of SPD operations, whilst still protecting the wiring from overheating when the SPD fails.

A fuse fitted in series with the SPD can allow the equipment to be damaged by the surge that destroys the SPD even as it opens the SPD's fuse. Even if the equipment is still operational afterwards, it will no longer be protected.

A fuse fitted in the common supply line that also powers the protected equipment will remove the power from the equipment when it opens. It is usually possible to rate a fuse so that it will protect an equipment from overcurrents whilst also being robust enough to survive large numbers of surges due to SPD activity. This is the most common design method, but may not be thought acceptable in some critical applications.

In some applications, fuses may be needed to protect SPDs used on signal lines from overheating, for example during a 'power cross' (when there is a short-circuit between a power conductor and the signal conductor). In some applications PTCs (positive temperature co-efficient thermistors, often described as 'self-resettable fuses') may be used instead of traditional fuses, allowing the system to function again without damage when the overvoltage has been removed without needing fuse replacement or the attentions of a service engineer.

## **5.5 Protecting from non-lightning surges**

### **5.5.1 Nuclear electromagnetic pulse (NEMP) and EMP**

NEMP and EMP are both superficially similar to lightning, but are between one and ten thousand times faster so even a dense network of air-terminations and down-conductors, or 3 metre mesh sizes for internal bonding networks, will not provide much protection. NEMP is the dominant effect (outside of the thermal and blast radius) of a nuclear bomb – from the point of view of an electronic device – and can damage electronic equipment at hundreds of miles distance. NEMP is outside the scope of this article, although information and guidance on it is readily available in military and civil defence publications and textbooks in the public domain.

EMP is an increasing concern when considering data security, terrorism, and criminal activities, since it seems that EMP 'bombs' which create little blast damage can be made without too much difficulty [24]. For more on this refer to the electronic warfare section (4.6) in [15].

### **5.5.2 Other external and internal surges**

Externally generated surges are especially common on incoming HV or MV power supplies, caused by the switching of large reactive loads, or load shedding by HV or MV switchgear or in the wider distribution network. External non-lightning surge sources also include telephone and data lines outside structures, usually due to shorting to mains cables when a vehicle knocks down a utility pole, or when a mechanical digger cuts through an underground cable conduit (sometimes called a 'power cross').

Very large currents from HV or MV earth faults can damage (even vaporise) signal or data cables which connect to a different building, and/or damage the equipment they interconnect. Even fibre-optic cables may not be immune to this if they use metal in their construction, unless the metal is stripped back far enough before entering the structure.

Internal surges can be caused by large on/off controlled DC or AC motors as their stored energy is released at switch-off, by the opening of a fuse (peak voltage typically double the peak of the nominal supply voltage), and by earth faults. At the more extreme end, a superconducting magnet in an MRI scanner or linear accelerator can source around 1MJ of surge energy when its field collapses.

Internally-generated surges are best controlled by segregating high power and sensitive equipment and their cables and power supplies as described in [10], and providing a good low-impedance MESH-BN (or a number

of MESH-IBNs). But where surges originate within a protection zone it may be difficult to stop the other equipment in the zone from being exposed, and SPD or filtering techniques may be needed.

Where significant non-lightning surges exist, the exposure levels suggested by lightning standards such as [3] and [4] may need to be increased, requiring upgrades in one or more of the lightning protection measures.

## 5.6 References and further reading

- [1] “*EMC for systems and installations*”, Tim Williams and Keith Armstrong, Newnes, 2000, ISBN 0 7506 4167 3.
- [2] “*IEE Guide on EMC and Functional Safety*”, IEE Publications September 2000, available to all as a free download (as a ‘Core’ document plus nine ‘Industry Annexes’) in either Word or PDF format from <http://www.iee.org.uk/PAB/EMC/core.htm> (note: the URL may be case sensitive).
- [3] “*Protection of structures against lightning - Part 1: General Principles*”, DD ENV 61024-1:1995, ISBN 0 580 24306 0 (available from BSI).
- [4] “*Protection of structures against lightning*”, BS 6651:1999 from the British Standards Institution (BSI).
- [5] “*Surge protection for the broadband co-axial plant – one piece of the puzzle*”, C.S. Blichasz, presented at ERA’s “Lightning Protection 98: buildings structures, and electronic equipment” conference, Solihull, 6-7 May 1998, ERA Technology Ltd, Leatherhead, UK, phone: +44 (0)1372 367 000, fax: +44 (0)1372 367 099, email: [info@era.co.uk](mailto:info@era.co.uk), web: <http://www.era.co.uk>
- [6] IEE Computing and Control Engineering Journal, April 1998, pages 57 – 60.
- [7] “*The explosions and fires at Texaco Refinery, Milford Haven, 24th July 1994*” HSE Books, May 1997.
- [8] “*Bonding the screens of cables at both ends*”, Keith Armstrong, ERA conference “*Earthing 2000*” Solihull July 2000, pp 2.3.1-2.3.12, ERA Technology Ltd, Leatherhead, UK, phone: +44 (0)1372 367 000, fax: +44 (0)1372 367 099, email: [info@era.co.uk](mailto:info@era.co.uk), web: <http://www.era.co.uk>
- [9] “*A bolt of danger*”, Jerome Kerr, Wireless Design and Development European Edition, 9.2000, pp 28-29.
- [10] “*EMC for systems and installations – Part 2 EMC Techniques for Installations*”, Keith Armstrong, EMC+Compliance Journal April 2000, pp 8-17. Available from the archives at: [www.emc-journal.co.uk](http://www.emc-journal.co.uk).
- [11] “*Surge protection devices – Installation issues*”, Ian Braithwaite, presented at the IEE colloquium on Surges, Transients, and EMC at the IEE, Savoy Place, London, on 18<sup>th</sup> February 1998, included in IEE colloquium digest reference number 1998/197.
- [12] “*Protection against lightning electromagnetic impulse – Part 1: General principles*”, IEC 61312-1: 1995.
- [13] “*Bonding configurations and earthing within a telecommunications building*”, ITU Recommendation K.27 (1996). ITU doc’s can be downloaded from <http://www.itu.int/publications/bookstore.html> for a small fee.
- [14] “*Systematic approach for the analysis of the electromagnetic environment within a building during lightning strike*” A. Orlandi, C. Mazzetti, Z. Flisowski, and M. Yamarkin, IEEE transactions on Electromagnetic Compatibility November 1998 Volume 40 Number 4 ISSN 0018-9375 Part II (special issue on Lightning), pp 521-535.
- [15] “*EMC for systems and installations – Part 4 Filtering and shielding*”, Keith Armstrong, EMC+Compliance Journal August 2000, pp 17-26. Available from [www.emc-journal.co.uk](http://www.emc-journal.co.uk).
- [16] “*Risk assessment of damages to telecommunication sites due to lightning discharges*”, ITU Recommendation K.39 (1996).
- [17] “*IEEE Recommended practice on surge voltages in low-voltage AC power circuits*”, IEEE C62.41-1991 (recognised as an American National Standard).
- [18] “*Electrical installations of buildings – Part 4: protection for safety – Chapter 44 Protection against overvoltages – Section 443 Protection against overvoltages of atmospheric origin or due to switching*”, IEC 60364-4-443 Edition 2.1 1999.

- [19] “*Insulation coordination for equipment within low-voltage systems – Part 1: Principles, requirements and tests*”, IEC 60664-1:1992
- [20] “*Safety requirements for electrical equipment for measurement, control, and laboratory use – Part 1: General requirements*”, EN 61010-1:1993 +A1 + Corr.1.
- [21] “*Electronic systems protection handbook*”, W.J.Furse & Co. Ltd, publication ref: ESPHB1, phone 0115 986 3471, fax 0115 986 0538
- [22] “*Lightning Protection 98: buildings structures, and electronic equipment conference*” Solihull, 6-7 May 1998, ERA Technology Ltd, Leatherhead, UK, phone: +44 (0)1372 367 000, fax: +44 (0)1372 367 099, email: info@era.co.uk, web: <http://www.era.co.uk>
- [23] “*Design techniques for EMC – Part 3: Filters and surge protection devices*”, Keith Armstrong, UK EMC Journal, June 1999, pp 9-16. Available from [www.emc-journal.co.uk](http://www.emc-journal.co.uk).
- [24] “*Just a normal town...*”, New Scientist, July 1<sup>st</sup> 2000, pp 20-24
- [25] “*Banana Skins (No. 17)*”, The UK EMC Journal, June 1998, page 6 (available from the archive at [www.emc-journal.co.uk](http://www.emc-journal.co.uk))