



Another EMC resource
from EMC Standards

Bonding cable shields at both ends to reduce noise

Helping you solve your EMC problems

Bonding cable shields at both ends to reduce noise

by Tony Waldron and Keith Armstrong

Published in the May 2002 edition of the EMC + Compliance Journal (www.compliance-club.com), pages 14-27

Table of contents

1	Synopsis	1
2	Introduction	2
3	The cables tested.....	5
4	The sources tested.....	7
5	The audio test gear used.....	7
6	The test set-ups used.....	8
7	Test results analysed by CMRR.....	10
8	Analysis of cable equivalent circuit.....	12
9	Analysis of the effect of the building's ground system impedance.....	16
10	Some related issues.....	21
11	Poor equipment design is the real cause of 'ground loop' noise.....	23
12	Conclusions.....	24
13	References.....	25

1 Synopsis

Many equipment designers, including some in professional audio companies, have found that radio-frequency (RF) bonding the shields of cables to chassis/frame/enclosure at both ends helps greatly with EMC Directive compliance. They have also found that it does not compromise the signal quality when the equipment is installed – despite permitting power-frequency ground loop currents (earth loops) to flow in the cable shields. Professional audio companies using this technique have found that it also saves a great deal of time during installation and commissioning.

But, in many industries, ground loops are anathematised by long-standing tradition as a significant cause of noise in the cables' signals. This aversion to ground loops is especially strong in the professional audio industry, which uses balanced cables for audio signals and often goes to extreme lengths during installation and commissioning to prevent ground loops.

This article addresses the ground-loop concerns in the pro-audio industry, but its results are easily applied to balanced (differential signalling) and unbalanced (single-ended signalling) shielded cables used in other electronic application areas, for both analogue and digital signals. Its conclusions will be of value wherever ground loop currents in cable shields are currently avoided in the attempt to improve signal/noise ratios or noise margins.

The authors found plenty of anecdotes but few hard facts when investigating the effect of ground loops on signal noise, so performed some tests themselves and reached some very interesting and valuable conclusions. This article describes tests we performed on a variety of balanced audio cables nearly 30m long with metallised foil or braid shields, to determine the effects of power-frequency shield currents (ground loop currents) on noise. Several types of balanced audio cables were tested, including an extremely poor quality balanced audio cable with untwisted signal conductors and a capacitive imbalance exceeding 20%.

Analysis of the test results revealed, to the authors' surprise, that power frequency currents in metallised foil or braid shields do not inductively couple significant noise into their internal conductors even at current levels which cause the cables to warm up. However, the voltage between the cable's shield and its internal conductors is a significant source of noise for balanced signals which have high impedances to ground. For good quality pro-audio balanced cables and equipment, the signal noise created by the equipment's common-mode rejection is comparable with that created by capacitive imbalance in the cables.

It appears that traditional equipment design methods that connect cable shields to conductors *inside* equipment are most probably to blame for the problems which have been blamed on ground loops. Equipment constructions that bond cable shields directly to the chassis/frame/enclosure are better for EMC compliance and allow signals to achieve the highest levels of quality regardless of the ground loop currents flowing in their cable shields.

2 Introduction

Professional audio equipment and systems supplied in the European Union (EU) must meet the EMC Directive, and unless they use its Technical Construction File (TCF) route to compliance pro-audio suppliers must declare conformity to EN 55103-1:1997 and EN 55103-2:1997 – the product-family harmonised EMC standards for audio, video, audio-visual and entertainment lighting control apparatus for professional use [1], [2]. Other types of equipment have other EMC standards applied.

When the EMC emissions tests are properly applied to equipment, systems or installations it is generally found that unless the shields of their external cables are radio-frequency (RF) bonded at *both* ends of their cables –

- Equipment which uses digital control and/or processing (e.g. which contains a microprocessor) or switch-mode technology will generally fail the emissions tests
- Equipment which uses analogue signal processing will generally fail the continuous RF immunity tests

RF bonding techniques which work well at radio-microphone, cellphone and wireless LAN frequencies (e.g. up to 2.5GHz for IEEE 802.11b, also known as Wi-Fi) require cable shields to be terminated using 360° electrical bonds between the shield and the cable connector shell, between that shell and the shell of the equipment's mating connector, and between that shell and the equipment's chassis/frame/enclosure. 360° bonding is sometimes called peripheral bonding or circumferential bonding.

On the other hand, cable shields which are only bonded at one end cease to provide shielding when their length exceeds one-tenth of the wavelength of the frequencies to be shielded against, so for example a cable 10m long only provides any significant shielding for frequencies below 3MHz. When cable lengths exceed one-quarter of a wavelength, shields which are bonded at one end only can become very efficient RF antennas – radiating RF noise and picking up RF from the environment more efficiently than if there was no shield at all. Although the RF noise in pro-audio products is usually caused by digital and switch-mode circuits, it appears as common-mode (CM) noise on all the analogue inputs and outputs too.

The problem is that in the professional audio industry there is a long-established tradition of bonding cable shields at one end only, to prevent 'ground loop' currents from flowing. Ground loop currents are traditionally blamed for increasing the levels of hum and other mains-borne noises in the audio signals. In some installations cable shield currents can be so high as to overheat a single cable, making it unreliable and possibly even causing safety risks.

Unfortunately, in a complex modern pro-audio installation the best way to bond the cable shields when using single-ended bonding is not always obvious, and it can take a great deal of time for even very skilled installers to determine the unique optimum solution when commissioning a pro-audio system. This time-consuming exercise often needs to be gone through again every time the system is changed.

From the above it might be concluded that there is an impasse – either we have pro-audio products, systems and installations that use one-ended shield bonding and have good audio quality but fail EMC compliance – or we use double-ended shield bonding and achieve EMC directive compliance but with poor audio quality.

One way that is often suggested to overcome this dilemma is to electrically bond a cable shield to the protectively-grounded chassis/frame/enclosure at one end, and 'RF bond' it using a capacitor in series with the bond at the other end. The idea is that good RF bonding is achieved at both ends, aiding EMC compliance, while ground loop currents (at power frequencies) are prevented from flowing.

(Protective grounding is necessary for the safety of all mains-powered equipment that is not 'double insulated'. Protective grounding is sometimes called protective earthing, but because 'ground' and 'earth' are such misused and abused terms it would be better to use the phrase 'protective bonding' instead. A structure's protective ground (earth) network is best called a protective bonding network, and the word 'earth' reserved solely for the soil-penetrating electrodes that connect to the mass of the planet Earth. Having made these comments, 'protective ground', 'protective grounding', 'grounding' and 'bonding' are the terms used here.)

The problem with the capacitor-at-one-end approach is that capacitors with good RF performance over a wide frequency range are costly and must be designed to fit within the bodies of the cable connectors. The inductance inevitably associated with fitting capacitors to connector pins with flying leads or by a printed circuit board (PCB) reduces their series-resonant frequencies and diminishes the range of frequencies over which they are effective.

The authors have received an estimated price of US\$4 each from Metatech Corporation (www.metatechcorp.com) in October 2001 for 1000-off quantities of an EESeal™ RF capacitor assembly which fits inside the shell of a 3-pin XLR connector (the traditional pro-audio balanced cable connector) and 'RF bonds' pin 1 of the XLR – the pin used for shield bonding – to its metal shell and hence to the chassis/frame/enclosure of the equipment. Even at the 10,000-off price estimate of US\$2.25 each this is a costly modification considering that XLR connectors usually cost between US\$1.50 and \$3.00.

Despite the fact that EESeal™ devices provide much better RF performance than any type of capacitor that could be connected externally to an XLR connector, Figure 1 shows that they only perform very well over a limited range of frequencies, depending on their capacitance value. So there can be no guarantee that any given capacitance value will enable a particular product to meet the 150kHz to 1GHz emissions and immunity tests in [1] and [2].

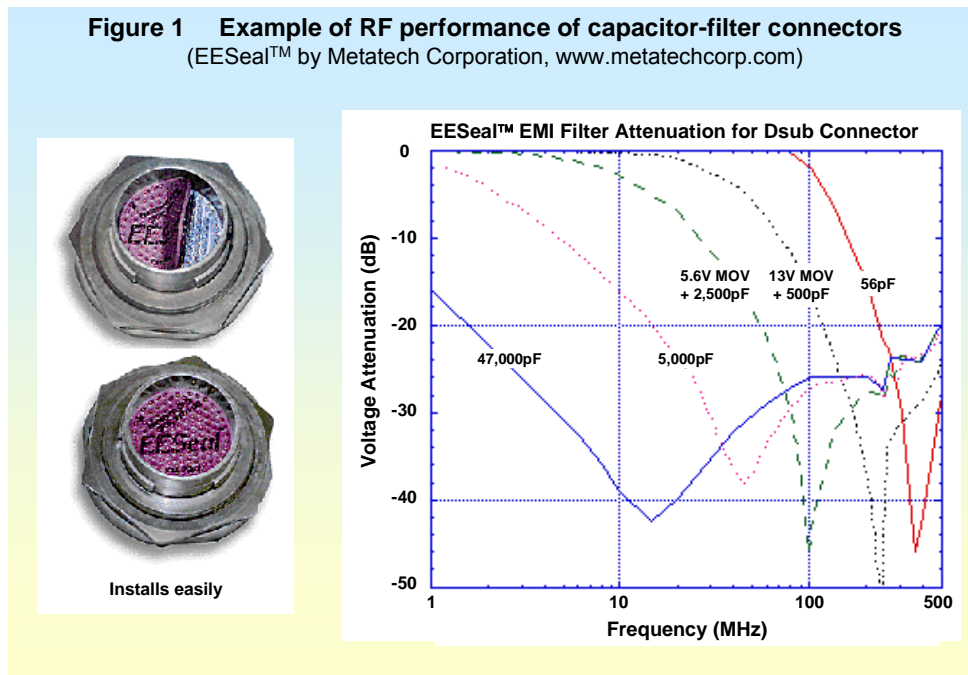

Higher-performance RF capacitors, such as annular or feedthrough types, could possibly be designed into XLR connectors and provide much better performance over a wider frequency range, but they are likely to be very much more costly than the EESeal™ example given above.

Another problem with the capacitor-bonding-at-one-end technique is that it does not remove the problem of deciding which end of the shield of each cable should be directly bonded to the grounded equipment. This probably means that interconnections would need to be fitted with RF-bonding capacitors between their shield and chassis/frame/enclosure at *both* ends, knowing that one end would have its capacitor shorted out. This method would add to material costs without reducing the traditionally long installation and commissioning times.

Single-ended shield bonding permits very high surge (transient) over-voltages to exist at the unbonded cable ends [9], mostly caused by lightning. Modern steel-framed buildings provide a reasonable amount of shielding from such atmospheric disturbances, but older wooden or brick buildings will not provide as much and open-air venues provide none. Cloud-cloud lightning within 2 miles radius couples well with horizontally-run cable shields and can inject 100V per metre (1kV for 10m length, 10kV for a 100m length). Cloud-cloud lightning is at least 10 times more common than cloud-ground strokes. Lightning experts have seen arcing occurring at the unbonded ends of shielded cables during thunderstorms. Unreliability of electronic equipment and increased safety hazards can therefore be a feature of installations that use single-ended shield bonding, unless surge protection devices are liberally applied. In some installations, connecting cable shields to ground via RF capacitors will place those capacitors at risk of damage from surges. Read chapter 9 of [6] for more about lightning protection for electronic systems.

Capacitive shield-to-ground bonding *can* be a useful 'fix' for individual interference problems in existing installations, especially when using good products like EESeal™ and spending some time finding the best capacitor value, and especially when they are used to filter the signals on the balanced conductors

(additional capacitors hardly add to the EESeal™ unit cost). But taking all the above into account we cannot recommend the use of RF capacitors to connect cable shields to ground it as a technically effective or cost-effective method suitable for universal application to pro-audio interconnections.

IEC 61000-5-2:1997 [4] describes the best practices to use for grounding and cabling to achieve EMC in installations. It is referenced by many of the latest standards on installing telecommunications and computer systems. [5] and [6] are additional references for people interested in the techniques described in [4].

Some pro-audio products manufacturers, system integrators and installers, such as Cadac Electronics Ltd (see Figure 2) have found that [4] works very well indeed when applied to pro-audio installations – allowing them to comply with [1] and [2] whilst also achieving very high quality audio. Also, as the electromagnetic noise in modern environments continues to rise and as digital processing is increasingly used for pro-audio and co-located equipment, compliance with the EMC immunity standard [2] is increasingly found to be important for the achievement of good quality audio.



[4] recommends directly bonding cable shields at both ends using 360° RF bonding techniques. It also recommends using a "Parallel Earth Conductor" (PEC) with a lower impedance than the shields, where necessary, to divert a large proportion of the power-frequency ground loop currents away from the shields and preventing them from overheating. A PEC can be a dedicated conductor, or it can be new or existing metalwork, as long as it is bonded to the frame/chassis/enclosure of the equipment at both ends of the cables concerned (effectively in parallel with their shields). In many pro-audio installations there are usually large numbers of shielded cables following any given route. Bonding all their shields at both ends would considerably reduce the currents flowing in each shield below the levels which could cause overheating – so an additional PEC might not be needed.

A very valuable benefit of employing [4] is that the days (sometimes weeks) that skilled installers usually spend trying to find the best way to bond the ends of each of hundreds of cable shields to minimise hum and noise is no longer needed. Products designed to use the techniques described by [4], and installed accordingly, generally achieve excellent audio quality immediately – by design. If a system/installation is changed – providing the techniques described in [4] are still followed – excellent audio quality is again achieved automatically without the need for highly-skilled modifications to the cable shield grounding scheme.

So the use of [4] permits the design of products and systems that are EMC compliant for legal supply in the EU, have the desired audio quality, and save a great deal of time (and money) in their installation. The additional material costs and assembly time required to implement [4] in products and systems is small, and in any case is vastly outweighed by the time and cost (and, increasingly, audio quality) benefits it achieves.

The effective use of the techniques described by [4] require that the electronic equipment connected at each end of the cable bond all cable shields directly to their low-impedance chassis, frame, cabinet, or enclosure

to prevent the 50/60Hz currents in the shields from interfering with their audio circuitry. This shield-bonding technique is already commonplace in telecommunication and computer equipment, where it is usually necessary for the maintenance of adequate signal integrity as well as for EMC compliance.

Unfortunately, many of the cable connectors traditionally used in the pro-audio industry (e.g. XLRs) do not yet permit 360° shield-bonding direct to the chassis/frame/enclosure. Instead, they connect to the shield using one of their connector pins, necessitating a 'pigtail' type of wired shield-chassis connection. Pigtail shield connections are singled out for attention by [4] as very bad practice, but careful attention to detail such as pigtail length and routing, and the use of RF filtering, have allowed short pigtails to be used in some EMC-compliant pro-audio equipment. Products that employ powerful digital signal processing or high-speed data links may have EMC compliance problems with any practical length of pigtail or connector pin. The use of pigtails and connector pins for shield bonding is likely to become more problematic if/when the EU's EMC emissions and immunity tests are extended beyond 1GHz, as they are likely to be in a few years time.

Despite the very good results achieved for both EMC compliance and audio quality by following [4], the pro-audio industry is in general still very wary of bonding cable shields at both ends. The long-established tradition of avoiding ground loops at any cost appears to have led to the commonly-held view that cable shield currents *directly* cause hum and noise problems due to *noise coupling within the cables themselves*.

The authors could not find any published papers, articles or data on the details of the noise coupling caused by shield currents in balanced audio cables, so decided to test a few cables to find out why [4] gives such good results in pro-audio installations.

Tests were done on a variety of balanced audio cables to measure the coupling of 50Hz cable shield currents into their balanced signal conductors, and these are described and analysed below. Their results have proved enlightening to the authors, and we hope that they will be of great interest and value to others in the pro-audio and other industries.

3 The cables tested

Five different types of cables were tested, and their known parameters are listed in Table 1 along with that of the parallel ground conductor (PEC). Each cable had standard XLR connectors fitted at both ends.

Table 1 Cable parameters

Cable ref:	Cable type (balanced audio cable except where stated)	Length (m)	Shield DC Ω (inc. XLRs)	Cap. per meter (per conductor)	Cap. imbalance	Total cap. (each conductor to shield)	Comments
A	Belden 1800F 'digital' cable	9.00	0.180	232pF	120pF, 5.74%	2.09nF	'High quality' balanced cable, braid shield.
B	Belden 8412 often used in US installations	27.6	0.481	191.7pF	130pF, 2.45%	5.29nF	Has a UL fire rating, braid shield.
C	Connectrix STX	6.5	–	300pF	18pF 0.92%	1.95nF	Low-cost type used inside 'Studioflex'.
D	Starquad (Canford Audio)	3.0	–	265.5	47pF 5.5%	796.5pF	Used by the BBC (two samples measured).
E	Unknown type, used in some installations before 1978	27.6	0.856	192.2pF	70pF, 1.32%	5.31nF	Black/clear conductors, aluminium foil wrap shield with drain wire, grey PVC jacket.
F	Farnell 140-459 (Alacatel)	27.6	0.436	399.1pF	270pF, 2.45%	11.02nF	Flexible screened twisted pair 16/0.2mm, red/blue conductors braid shield, black PVC jacket.

G	RS 367-656 straight multiconductor, <i>not intended to be used as a balanced audio cable</i>	27.6	0.302	472.6pF	3.11nF, 23.8%	13.05nF	Intentionally imbalanced and untwisted 'very poor quality' cable, braid shield. 25 conductors of 7/0.1mm. 14 conductors connected in parallel for one signal conductor, 8 in parallel for the other.
PEC	RS 358-242 green/yellow ground cable	27.6	0.081 (with no XLRs)	N/a	N/a	N/a	84/0.3mm strands. 6mm ² cross-sectional area of copper.

Cables B, E, F, G and the PEC were all made into one bundle 27.6m long. This bundle was laid out on the floor in as wide a loop as was practical given the environment, partly shown by the photographs in Figures 3a and 3b. Cables A, C and D were not long enough to be included in the bundle so only a few measurements were made on them. Except for noting that their results were consistent with those from the 27.6m bundle cables A, C and D are not discussed any further here.

Figure 3a Part of the 27.6 metre cable bundle route
(and Keith Armstrong, one of the authors)

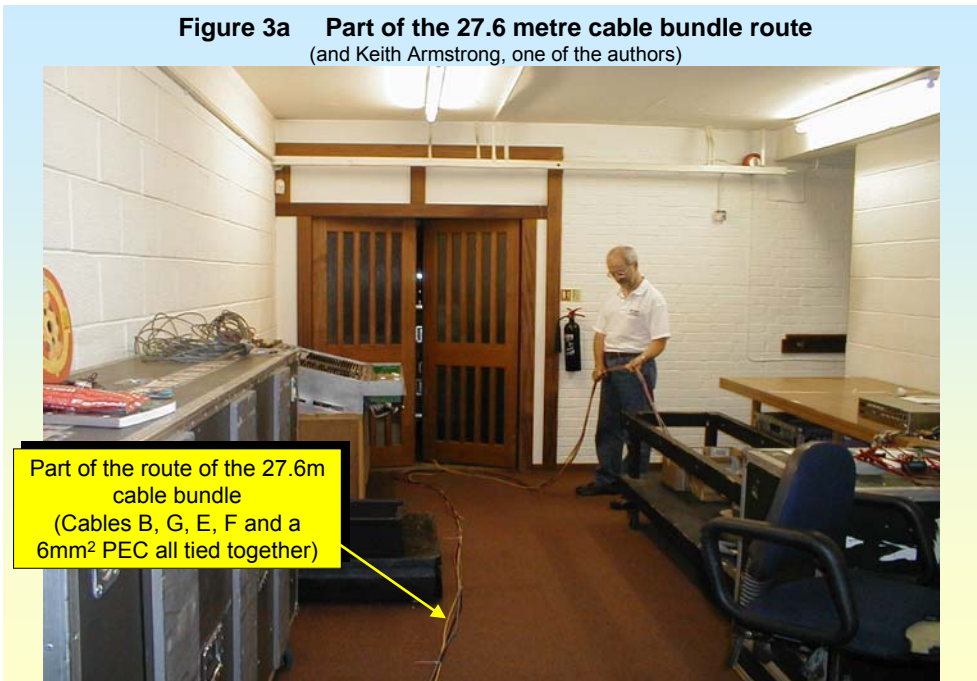
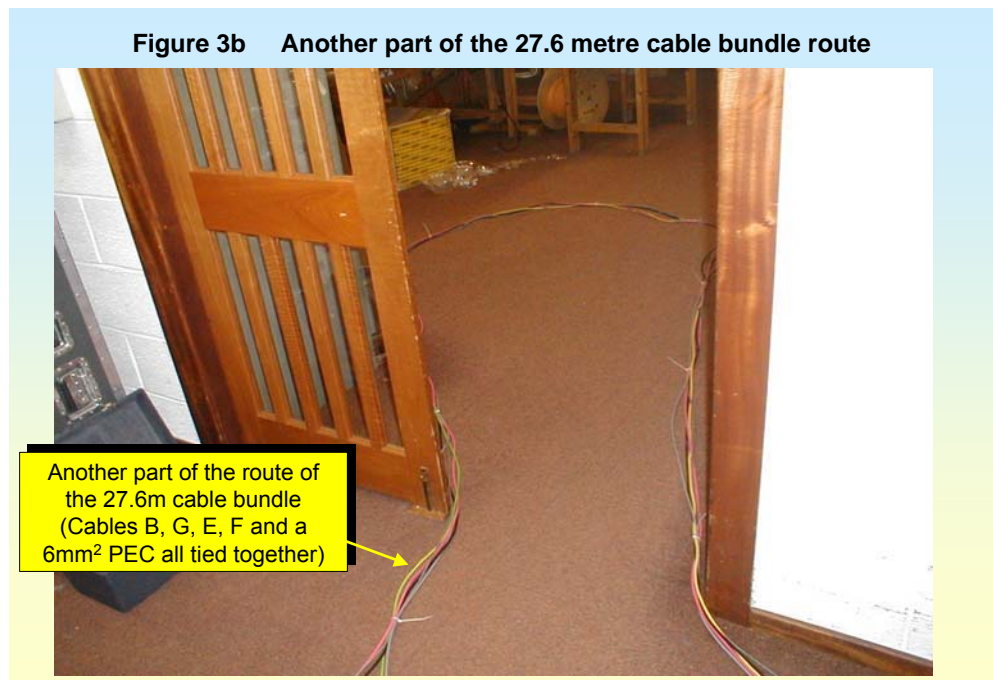

Figure 3b Another part of the 27.6 metre cable bundle route



As mentioned above and as shown by Table 1, cable G is an artificially imbalanced audio cable created by combining fourteen of the conductors in a straight 25-way multiconductor cable to create one of the balanced signal conductors, and eight of the conductors to create the other signal conductor. Three cores were left unused. This gave us a very poor capacitance imbalance of over 24%, with no twisting of the balanced signal conductors – probably a much worse cable than might ever have to be used, even in a legacy installation.

4 The sources tested

Four types of simulated source were chosen to cover a wide range of practical sources, shown by Figure 4.

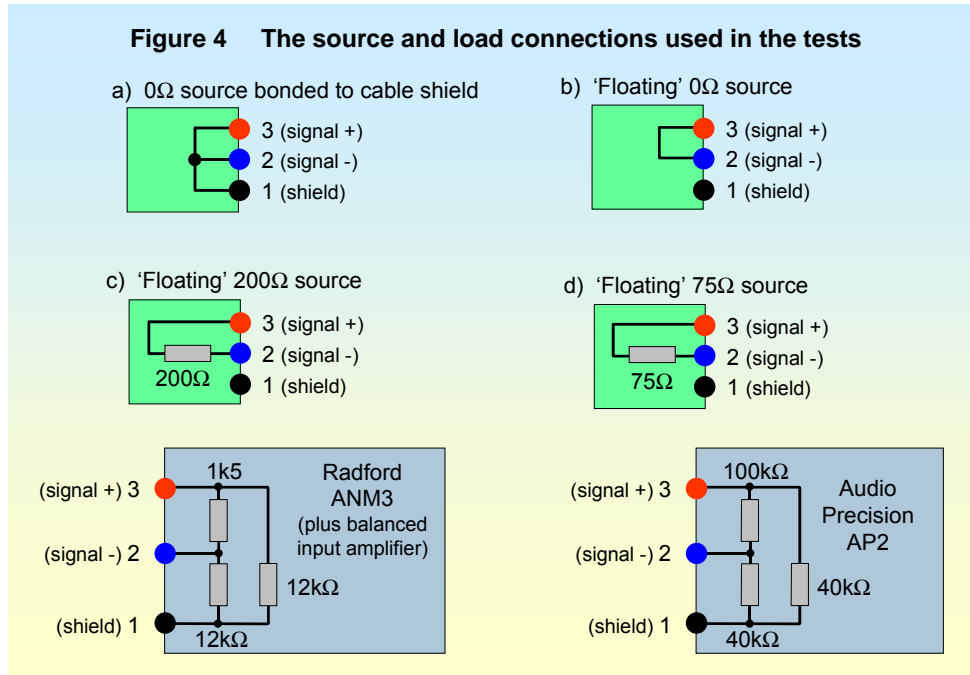

- a) 0Ω differential impedance, 0Ω common-mode impedance. Achieved by shorting all 3 pins of the XLR at the source end together. This simulates a low-cost electronic driver where each signal output is referenced by its amplifier to a common 0V rail connected directly to the cable shield, or a centre-tapped transformer winding with the centre tap connected to the shield.
- b) 0Ω differential impedance, very high common-mode impedance. Achieved by shorting the two signal pins of the XLR at the source end together and not connecting anything to pin 1 (cable shield). This simulates a 'floating' electronic driver, or the isolated secondary winding of a transformer driven from a low-impedance amplifier, both having a very high common mode rejection ratio (CMRR) at 50/60Hz.
- c) 200Ω differential impedance, very high common-mode impedance. Achieved by connecting a 200Ω resistor between the two signal pins of the XLR at the source end and not connecting anything to pin 1 (the cable shield). This simulates a moving-coil (dynamic) microphone.
- d) 75Ω differential impedance, very high common-mode impedance. Achieved by connecting a 75Ω resistor between the two signal pins of the XLR at the source end and not connecting anything to pin 1 (the cable shield). This simulates one of the transformer outputs from an XTA Electronics "DS800 Active Mic/Line Distribution System", a popular modern 8 input 32 output self-contained audio distribution product.

Pro-audio sources with finite CMRR do exist, but are not simulated by these tests.

5 The audio test gear used

Two items of pro-audio test gear were used: an Audio Precision AP2 computer-controlled audio test set, and a venerable Radford Audio Noisemeter type ANM3 – both of them very familiar to pro-audio engineers the world over. Their equivalent load impedances on the tested cable are shown by Figure 4 above. The Radford had been modified by the addition of a balanced input amplifier because in its original build state the Radford has an imbalanced (single-ended) input.

These two instruments were used to measure the differential-mode (DM) signal on the tested cable's centre conductors and reject the CM noise. CMRR is a measure of the imperfections in the receiving circuit that turn CM noise into unwanted DM noise (CM-DM conversion) in the wanted signal.

The CMRR performance of these two test instruments is listed in Table 2 below, and are representative of high-performance pro-audio equipment. It is relatively easy to make balanced-input amplifiers with better CMRR at 50/60Hz in the laboratory (such as the last item in Table 2, the “special instrumentation amplifier”) but not so easy to make commercially viable products with better than 80dB CMRR at 50/60Hz plus good CMRR also over the full audio frequency range of 20Hz to 20kHz.

Table 2 CMRR performance of the audio test gear

Audio test gear	CMRR @ 50Hz at various Common-Mode input voltages		
	200mV	2V	5V
Audio Precision AP2 Serial # 33276	100dB	91.5dB	85.9dB
Radford Audio Noisemeter ANM3 Serial # 90928 (with balanced input mod.)	82.3dB	82dB	74.6dB
Special instrumentation amplifier (only used for additional tests on cable F)	≥118dB	≥118dB	118dB

It was noted during the cable tests that many of the test results for cables B, E and F were limited by the CMRR performance of the test equipment, despite its good performance. Despite this, the measured values have been used even though the actual cable performance was likely to be much better, so as to err on the side of caution. Although this approach makes the cables’ performances appear worse than they really are, it makes the results of these tests more relevant and useful to practising pro-audio engineers because they show what kind of performance would be achieved from these cables in realistic pro-audio systems.

In addition to the above, a variety of other equipment was used:., e.g. true-rms digital voltmeters/ammeters, a capacitance meter, a Kelvin-bridge four terminal milliohmeter, an oscilloscope, clip-on ammeter, etc.

6 The test set-ups used

Three different test set-ups were used, as sketched by Figure 5:

- i) 5A (sometimes 10A) shield current
- ii) Current of 5A (sometimes 10A) in a combined PEC and shield
- iii) No shield current, but a shield voltage of 5V

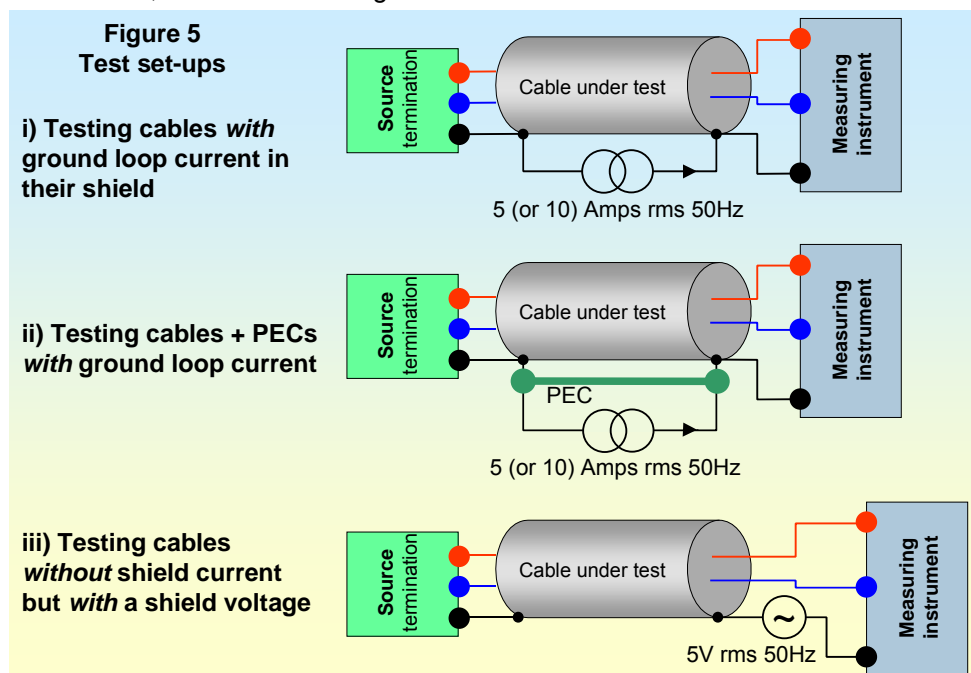

For each of the three test set-ups (i-iii), each sample of the four cables (B, E, F and G) was tested using each of the four source terminations (a-d) – 48 separate measurements in all.

In the first set of tests (i) an isolated 50Hz current generator was used to inject a current of either 5 or 10A into the tested cable's shield to simulate a long cable with its shield bonded to a protective ground network at both ends and suffering a ground loop current because of potential differences between its ends. Such large currents are considered untypical of pro-audio installations, but were used because of the difficulties found in measuring any increase in the DM noise caused by the ground loop currents. With 10A shield currents the cables were found to warm up noticeably.

The second set of tests (ii) was identical to the first, but with the 6mm² PEC that was included in the 27.6m cable bundle connected in parallel with the cable shield as described by [4]. The lower impedance (at 50Hz) of the PEC resulted in most of the injected current flowing in the PEC and only a small current in the shield. The currents were seen to divide according to the ratio of the resistances between cable shield and PEC (at 50Hz the inductances of the different current paths (shield or PEC) have a negligible effect, see later).

The currents used in all the above tests were set to the same values for ease of measurement. But in real installations the effect of reducing the impedance between two locations in the ground network would be to reduce the potential difference between them. The effect of this real-life behaviour is discussed in detail in section 9 and Figures 11a-d.

The final set of tests (iii) simulated a long cable routed as before but with its shield bonded at the source end only. To simulate the effect of the potential difference between the grounds at its ends, the tests applied a 50Hz voltage between the signal reference and shield at the load end. The voltage applied in test iii) was 5V, which is considered untypically high for a pro-audio installation, but was used because the resulting 5V CM voltage was similar to that resulting from the current-driven shield tests i) and ii). When using single-ended shield bonding techniques there is generally a choice about which end of a shield to disconnect, and this set-up simulated the worst-case situation.

Figure 6 shows the practical set-up which was used to connect the four source types to each of the four types of cable at the start of the 27.6m bundle, connect the PEC in parallel with the cable shield, connect a measuring instrument to each type of cable at the end of the 27.6m cable bundle, and inject current or voltage into the cable shields. The two shiny areas, marked 'drive' and 'receive' were plain copper-clad PCBs, unetched and roller-tinned, used to connect the shields and the PEC to the current/voltage source with a negligible impedance by simply soldering them to these PCBs when required.

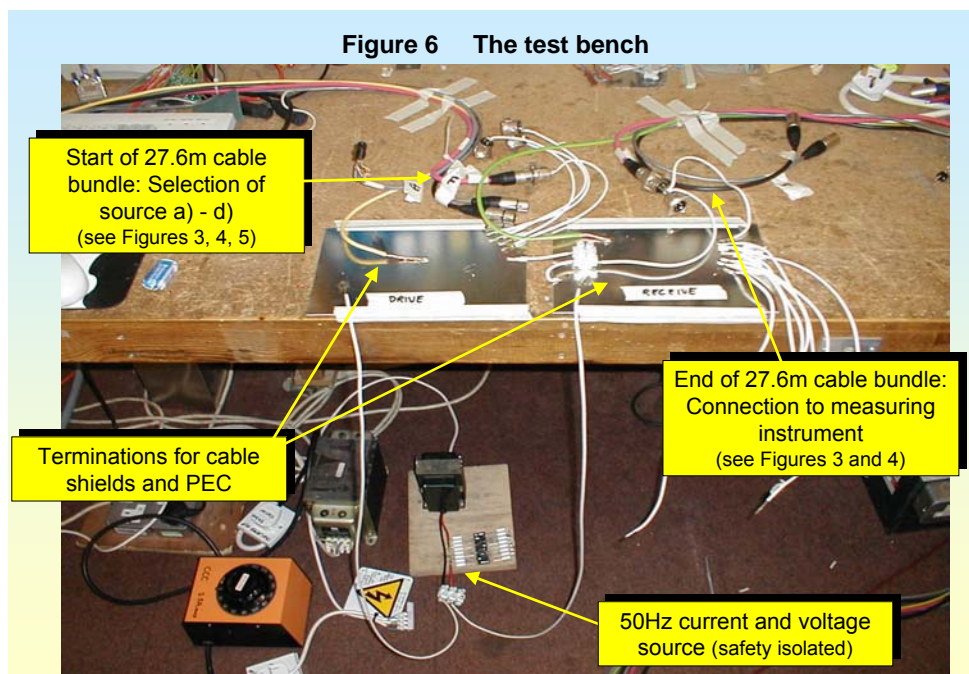

The 50Hz current/voltage generator was simply a variable transformer powered from the regular mains supply, driving a safety-isolating step-down transformer. A 0.10Ω high-power resistor was used in series with the output to monitor the output current. Due to the waveform distortion of the 50Hz output (typical flat-topping), the test currents and voltages were not pure 50Hz and contained some mains harmonics, helping the tests simulate real-life noise performance.

7 Test results analysed by CMRR

To help compare the results of the tests, the CMRRs for cables B, E, F and G were calculated for each of the four sources (a-d) and for each of the three cable tests (i-iii). The results are shown in Figures 7a-d. Since the results incorporate the finite CMRR of the measuring instruments, actual DM noise due to the cables alone would be lower than these figures suggest – but this simply means that our results are more representative of the CMRR performance that could be expected in real life. For the tests with a PEC (ii) the CMRR is calculated with respect to the CM voltage measured during test i), to calculate the CMRR of the cable shield/PEC combination.

Figure 7a shows the CMRR results for the source (a) for tests i)-iii). In test i) the typical shield resistance was around 0.5Ω , which with 5A flowing created a CM voltage of around 2.5V between shield and balanced conductors at the load. In test ii) the shield + PEC resistance was typically around 0.08Ω , which with 5A in it created a CM voltage of around 0.4V (some tests used 10A and had CM voltages of around 0.8V instead).

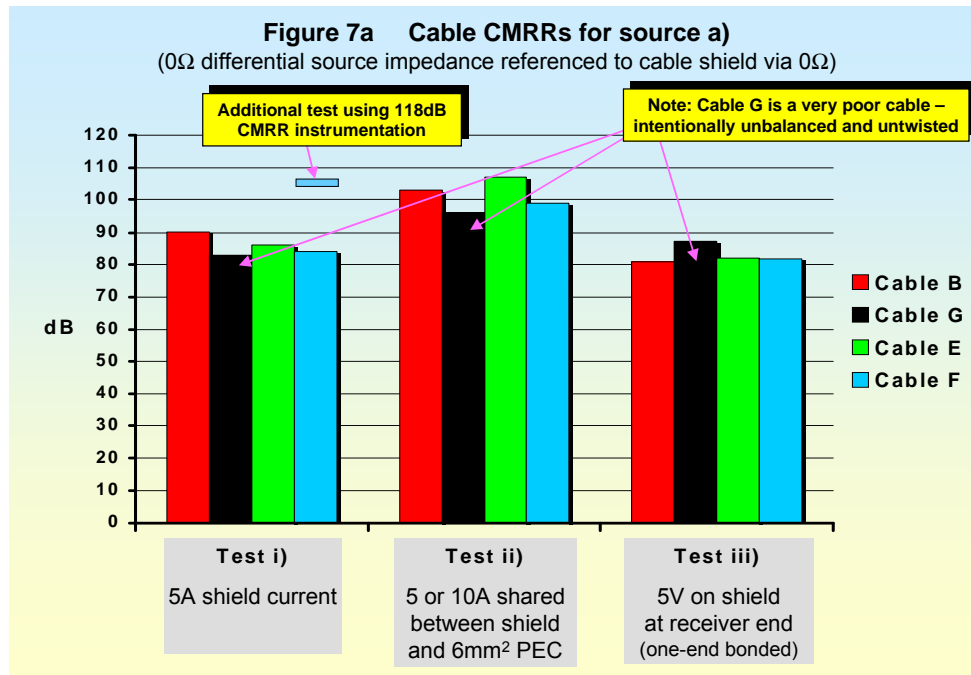

The CMRR values shown in Figure 7a are generally lower than those achieved by the other source terminations (see Figures 7b-c). This is because bonding the source to the shield creates the maximum values of CM voltage between shield and signal conductors at the load, which then gets converted into DM noise by the finite CMRR of the audio measuring equipment (typical of good quality pro-audio equipment).

Figures 7a-d show some additional tests made on cable F with the specially designed instrumentation amplifier (118dB CMRR at 50Hz, not typical of most pro-audio equipment). These tests showed an improvement of between 10 and 23dB in CMRR, indicating that what is being measured in these tests is the overall CMRR of the cables plus their test instrumentation, rather than the cables themselves.

Figure 7a shows that the both-end-bonded cables with 5A in their shields achieve about the same CMRR as the same cables with their shields unterminated at their load ends. However, when a PEC was added the CMRR improved by between 10 and 20dB, even with 10A of current.

Note that the intentionally bad cable (G) was only a very little worse than the other types on tests i) and ii). This is because the very low source impedances of source a) prevented its very large capacitive imbalance from having any significant effect. Its higher performance than the other types on test iii) in Figure 7a is probably due to the DM noise created by the cable's capacitive imbalance partially cancelling the DM noise created by the finite CMRR of the test equipment, due to phase differences between them.

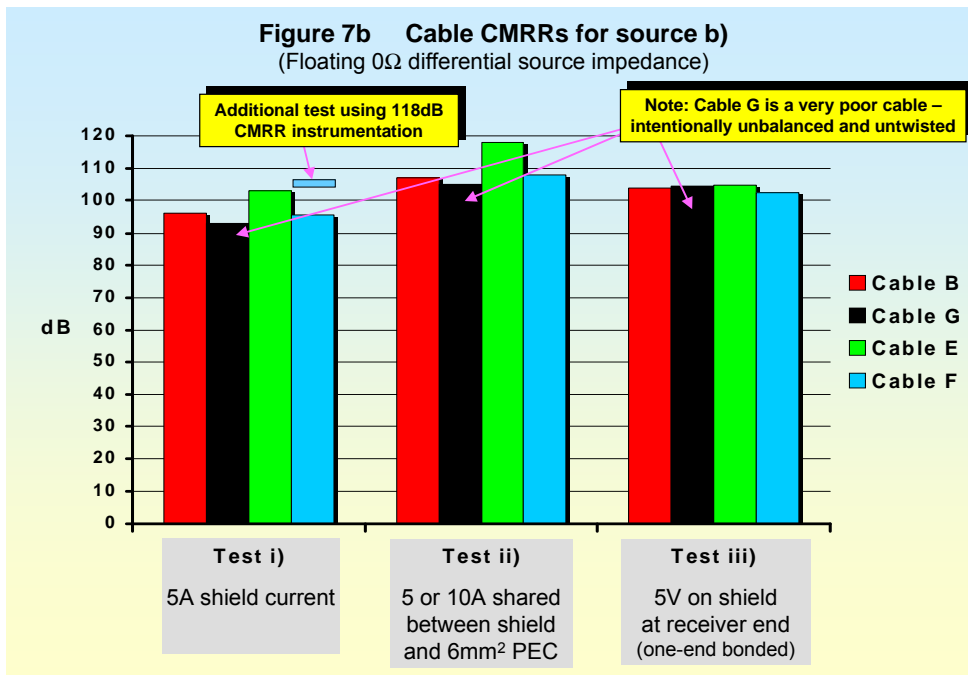

Figure 7b shows the CMRR results for the three tests with source b) for tests i)-iii). Because the source was completely 'floating' while the load had a finite CM impedance, most of the CM voltage between the shield and the signal conductors appeared at the source end and the load end experienced a much lower CM voltage than when source a) was used (Figure 7a).

Figure 7b shows generally higher CMRRs than Figure 7a due to the much lower CM voltages (typically 20 - 400mV) applied to the measuring instruments at the load. The tests (i) with shields bonded at both ends had the worst CMRR for source b). The tests using a PEC (ii) showed around 13dB improvement over i) and between 3 and 14dB improvement over iii).

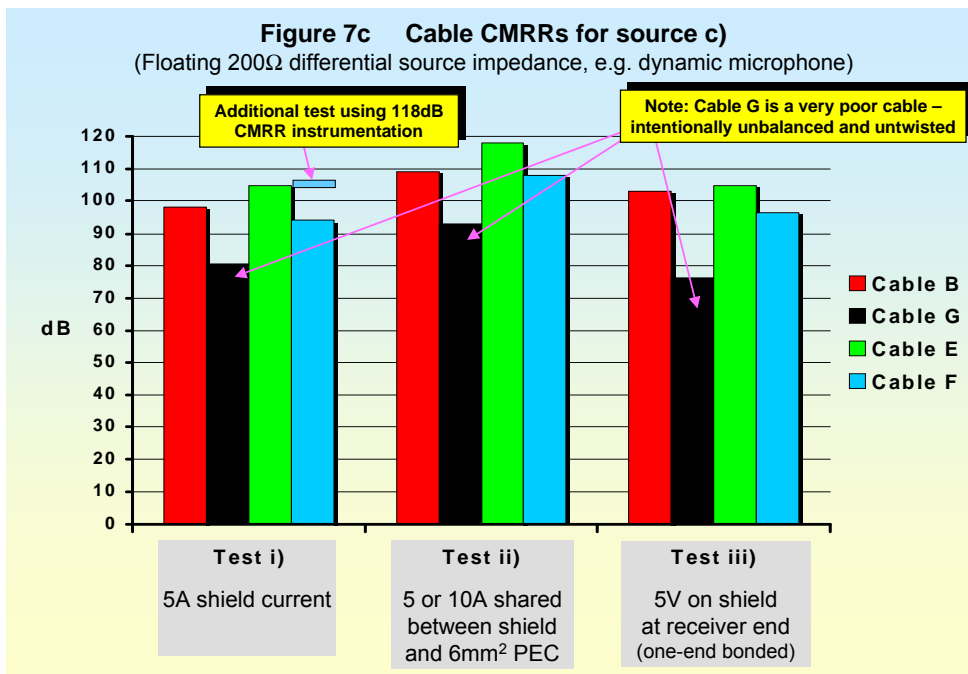

Figure 7c analyses the tests that used a floating 200Ω DM source (c) which simulates a typical dynamic microphone. Because the DM source impedance is now not zero, imbalanced noise currents in the signal conductors can have a significantly greater effect on the DM noise injection than it could with sources a) or b). Cable G – the intentionally badly balanced one – has a much poorer performance than the other cables as a result, whether it is carrying shield current or not.

The worst cable G result was obtained for the test with the shield unterminated at the load end (iii). With the shield bonded at both ends (i) and especially when combined with a PEC (ii) cable G gave better CMRR figures. This result implies that bonding the shields of very poor quality cables at both ends should *improve* their CM noise rejection.

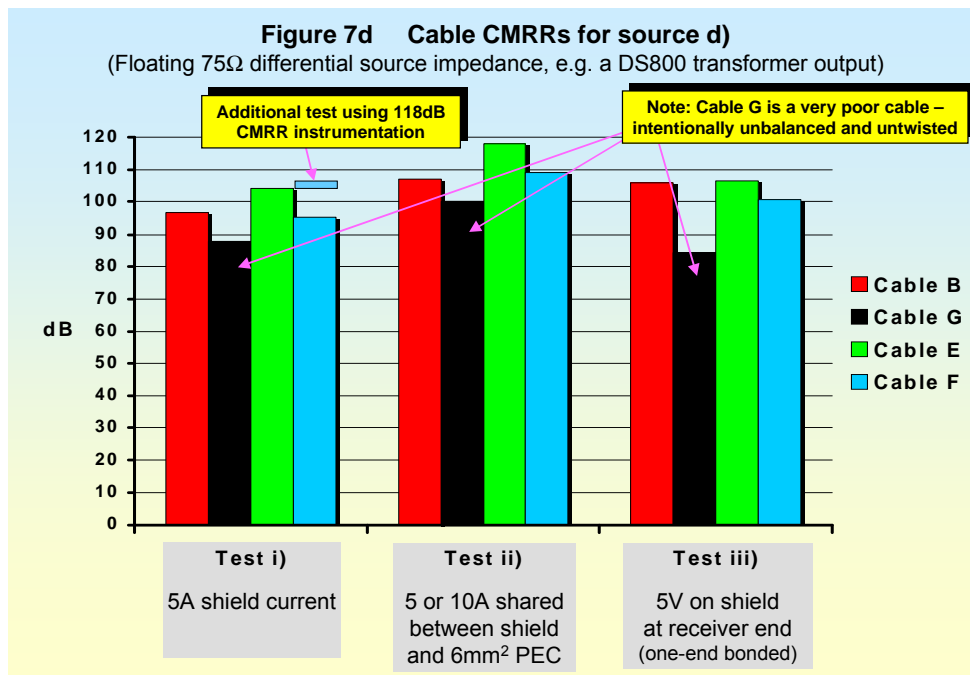

Figure 7d shows the results of the tests that used a floating 75Ω DM (d). The results generally lie between those of Figures 7b and 7c. This is particularly so for the intentionally bad cable (G), while the effect of the source’s DM impedance on the other cable types is not so marked.

We conclude from the results shown by Figures 7a-d that the CMRR resulting from bonding shields at both ends is usually about the same as when a cable shield is bonded to the grounded frame/chassis/enclosure at the source but not at the load. However, the CMRR of the cable/PEC combination is always the best.

Some might argue that the above results show that bonding cables at both ends cannot be good practice because the audio performance will not be as good as could be achieved by careful and installation-specific single-ended shield bonding. But this is too simplistic an argument because it ignores the interactions of the cables with real installations.

Real systems and installations have finite source impedances for their ground potential differences and aren’t the perfect voltage or current sources used in our laboratory tests and calculations above. In a real installation bonding a cable shield at both ends and/or connecting a PEC will reduce the potential differences between the equipment grounds at different locations, thereby reducing the ‘ground noise’ effects. Knowledge of the Thévenin equivalent source voltages and impedances for real ‘ground loops’ is therefore necessary to predict whether shield bonding at both ends will give good enough results in real applications. This issue is explored in detail in section 9 below, which shows that in real pro-audio installations the technique of bonding shields at both ends can be used to easily achieve predictably excellent audio performance.

8 Analysis of cable equivalent circuit

The detailed results we obtained during the tests described here allow us to describe the equivalent low-frequency electrical circuit for a balanced cable, taking into account all the features that affect the conversion of CM noise to DM, whether the CM noise is caused by shield voltage or shield current. Figure 8 shows the equivalent circuit we have determined for a balanced cable at 50/60Hz, and also shows the equivalent circuits for its source and load.

Figure 8 The equivalent circuit for a balanced audio cable (at 50/60Hz)

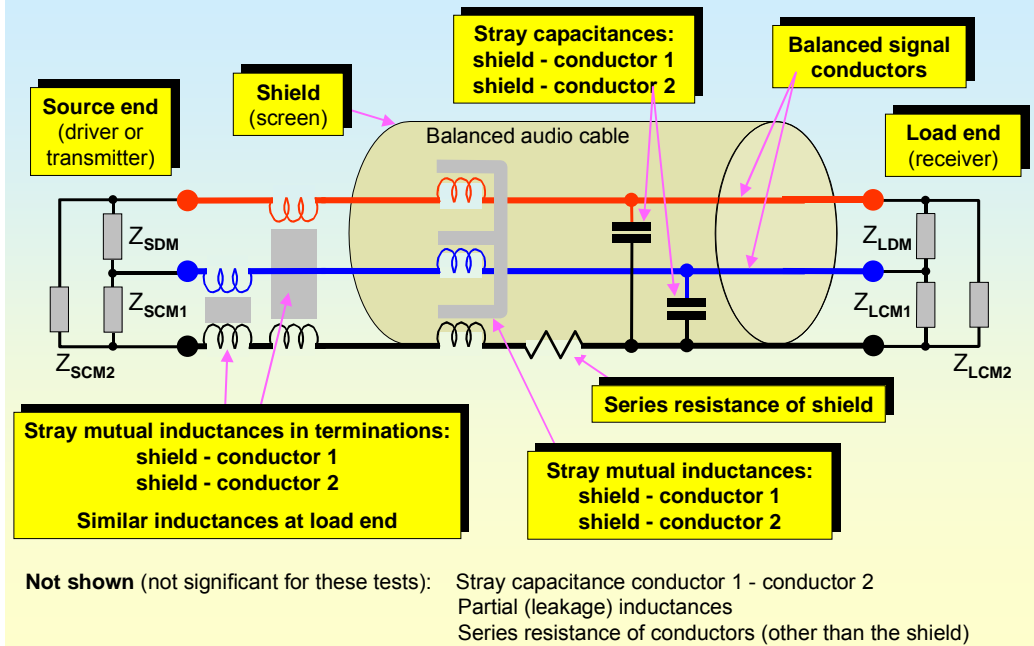

The cable's *source* has a differential-mode (DM) impedance Z_{SDM} , and each of its 'legs' has an impedance to the circuit's reference voltage (ground) of Z_{SCM1} and Z_{SCM2} which will be almost identical in any practical balanced circuit with reasonable CMRR performance. In real life these are associated with DM and CM voltage or current sources not shown by Figure 8. The cable's *load* has a similar equivalent circuit, with DM impedance Z_{LDM} , and CM impedances of Z_{LCM1} and Z_{LCM2} (again, almost identical in practice).

The balanced cable itself has a series resistance in each conductor and in its shield. Only the shield's resistance is relevant to these tests, because at 50/60Hz it limits the current that flows in the shield for a given applied voltage. The 'partial' or 'leakage' inductances of the shield or conductors are too small to have a significant effect (see section 10) at such low frequencies.

Stray capacitance

Capacitance exists between the two signal conductors, and between each conductor and the cable's shield. Because of the low impedances typically used for Z_{SDM} and the low frequency of the test (50Hz), the inter-conductor capacitance is not significant for the cable performance measured by these tests. However, the values and equality ('balance') of the capacitances between the two signal conductors and the shield are very significant even at 50/60Hz, because of the high CM impedances which can exist with many types of balanced source and are normal for balanced loads.

Z_{SCM1} and the conductor-shield capacitance of conductor 1 form a low-pass filter for CM noise originating from the source, as does Z_{SCM2} and the conductor-shield capacitance of conductor 2. As long as these two low-pass filters have *identical* time constants any CM noise voltage arising from the source cannot result in DM noise in the wanted signal at the load.

Where there is a CM voltage between the signal conductors and the cable shield, the stray capacitances between them will result in injected currents. If the currents injected into each signal conductor were *identical* and the source (and load) CM impedances were also identical, the CM noise voltage on the cable shield would not result in DM noise in the wanted signal.

Since in pro-audio equipment the CM impedances are generally accurately matched at the source and at the load, the balance of the stray capacitances between the signal conductors and the shield is significant. The matching of these stray capacitances is known as the capacitance balance of a balanced cable and it is a very important parameter because it governs the amount of CM-to-DM noise conversion which occurs in the cable itself.

Few practical balanced audio cables achieve a capacitance balance of 1% or better, with most lying between 1% and 6%. So where there are finite values of DM source impedance and high values of CM load

impedances, 50/60Hz CM voltages present at the source or on the cable shield will be converted into DM noise in the wanted signal, and could significantly impair the audio quality.

Capacitance imbalance is very important to this investigation, which is why cable G was created by the authors to have an intentionally poor capacitance balance of about 24%. Cable G simulates a cable that is so poor that no-one would choose to use it for pro-audio if they had any choice, but it is understood that such poor cables might possibly still exist in some legacy installations (although at least they will probably be twisted, unlike cable G).

Stray mutual inductance

This exists between the two conductors in a cable and the shield and we were expecting an imbalance in it to cause CM to DM noise conversion in the cable itself, in a similar manner to the effect of the capacitive imbalance. But we found (with the aid of additional tests having greater sensitivity than those described here) that the mutual inductive coupling between the shield and each signal conductor is approximately the same as the partial inductance of the cable shield – roughly 1 μ H per metre of cable.

The mutual inductances from the shield to each of the balanced conductors are inevitably very closely matched, because both conductors have exactly the same length surrounded by the shield. None of our measurements have been able to detect any DM noise generated within the cable as a result of the stray mutual inductance. The only consequence of mutual inductance that we have been able to detect is a small CM voltage between the balanced conductors and the shield, insignificant when compared with the CM voltage caused by shield resistance. For example – for the typical cables we tested with 5A shield currents the inductively coupled CM voltage was around 43mV, whereas the CM voltage due to shield resistance was around 2.5V, about 50 times larger.

We conclude that the mutual inductance inside a cable is so small and so well balanced (even for very poor quality cables such as G) that it has very little (if any) practical significance for CMRR. No doubt John Watkinson already understood this in 1996 when he wrote about the lack of harm caused to balanced audio signals when ground loop currents flow due to shields being bonding at both ends for EMC [7].

Mutual inductance imbalance in the cable could be increased where cables are jointed or repaired if the shield's 360° coverage is impaired, but tests on the mutual inductance of an XLR carrying the shield on pin 1 (see below) show that the mutual inductance resulting from such repairs is likely to be very low indeed.

Shield resistance

A shield's resistance generates a potential difference between the two ends of the shield, when shield current flows. This generates a CM voltage between the shield and the signal conductors, encouraging the cable's stray capacitances (see above) to inject currents into the balanced conductors. The inevitable imbalance between the stray capacitances then generates DM noise (depending on the source and load impedances, as described earlier).

Any voltage between the shield and the signal conductors for a shield which is terminated at only one end is constant along the whole length of the cable. But when a cable shield is bonded at both ends the shield voltage as seen by the internal conductors varies with the distance along the cable. Remembering that the 'lumped' cable stray capacitors and shield resistance shown in Figure 8 are really spread uniformly along the length of the cable, we can see that – for the same shield voltage at the load end – the cable with the shield bonded at both ends should experience only half the injected current via its stray capacitance compared with a cable whose shield is not bonded at the load end. This beneficial effect of bonding shields at both ends is only detectable in the results for cable G in Figures 7c and 7d – in the other tests the CM-DM conversion occurring inside the cables was swamped by the CM-DM conversion occurring in the measuring instruments.

Mutual inductances in the cable terminations

Figure 8 also shows the mutual inductances in the cable's terminations, which were minimised by the test set-ups and layouts used so that they contributed insignificant errors even with the high currents used. But when we consider the traditional methods of terminating the shields of audio cables, e.g. in XLRs by 'pigtailling' them to pin 1 and then pigtailling them again within the equipment, we can see that it is possible for the mutual inductance between one of the termination's signal conductors and the screen to be greater than for the other, due to asymmetry in the connector and in the routing of the pigtail with respect to the two signal conductors.

Tests carried out by one of the authors show that the mutual inductance imbalance between pins 2 and 3 for a mated pair of XLR connectors carrying shield current on pin 1 results in no more than 1 μ V of DM noise per

amp of 50Hz shield current. The overall length of the mated XLR pins was 50mm – longer conductor lengths create increased opportunities for imbalanced mutual inductances, and these are discussed in section 11.

Pro-audio manufacturers and installers who use the installation methods recommended by [4] to help achieve EMC compliance find that shield pigtailed must be kept very short and bonded directly to the chassis/frame/enclosure of the equipment for good EMC reasons. This analysis shows that this type of design is also a requirement for excellent inductive balance, and section 11 shows that it also prevents ground loops from flowing in or near audio circuitry and degrading audio quality.

Shield terminations can be improved, for both inductive balance and EMC purposes, when using XLRs. Most types of XLR cable connectors provide a shell-bonding solder lug, which can be linked with a short piece of wire to pin 1 and hence to the cable shield. Practical issues here are the mechanical contacts between the shells of the cable and chassis connectors, which may not be very reliable or may only be at a single point (not ideal for EMC); and the bond between the metal shell of the chassis connector and the equipment chassis itself may be compromised by paint or anodising, or may rely totally on the two standard fixing screws (not ideal for EMC). At least one supplier claims to have XLR cable connectors with improved shielding (“Swift” from Jenving Technology AB, www.jenving.se) but we know of only one that offers some XLR cable connectors with full 360° RF shield bonding – the “Digital XLR” from Neutrik USA Inc. (www.neutrik.com) shown in exploded view in Figure 9.

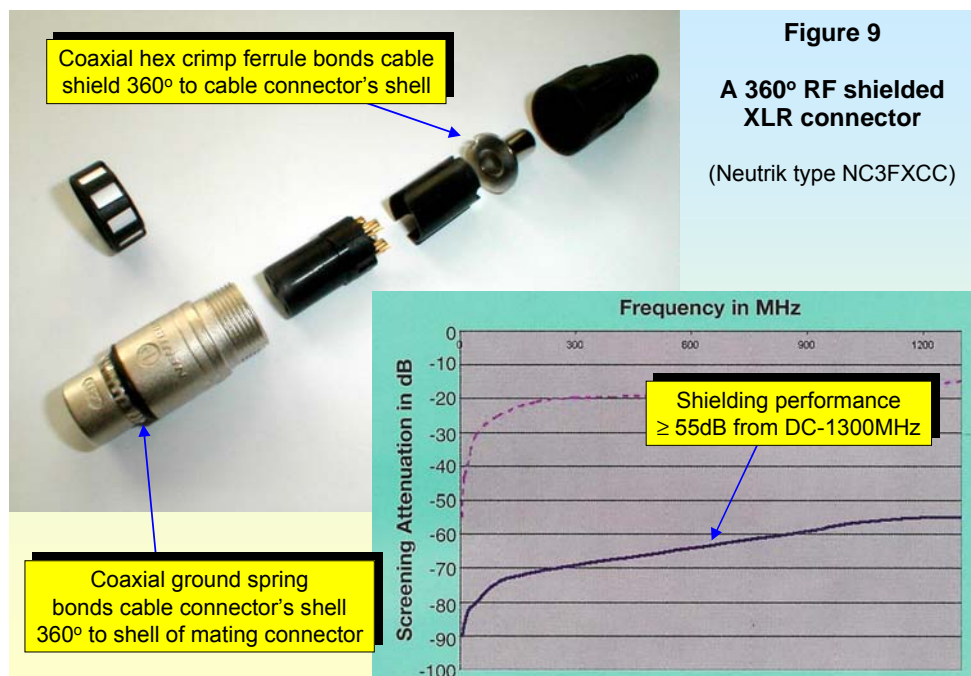

Using proper 360° RF shield bonding techniques in the connectors at each end of a cable is best for EMC, especially at wireless microphone, cellphone and wireless LAN frequencies. Such techniques do not use pigtailed or connector pins for shield bonding, so the inductive balance they provide is automatically perfect. In the UK the “Digital” female cable connector NC3FXCC costs about £2.50 in 1,000 off quantities, whereas the traditional NC3FX costs £1.32. The “Digital” male cable connector NC3MXCC costs around £1.56 at 1,000 off, whereas the traditional NC3MX costs £1.10. The additional costs of the “Digital” XLRs at each end are roughly comparable with adding a reasonably effective RF capacitor from pin 1 to chassis (in 10,000 off quantities) while the EMC benefits are considerably higher and more predictable.

Neutrik specify their “Digital” XLRs for use on digital pro-audio signals, but they are eminently suitable for controlling ground loops and providing EMC immunity for analogue pro-audio signals. Unfortunately Neutrik do not (yet) have equivalent 360° RF bonding XLRs for chassis mounting, but their B-series parts have a number of circumferential chassis bonding spring contacts (option E adds more contacts so should be better at higher frequencies) and some of the female B-series types also have a number of circumferential shell bonding spring contacts. Using these chassis connectors with the “Digital” cable connectors will probably achieve the best EMC performance, and the best inductive cable balance at 50Hz, that is currently available using off-the-shelf XLRs.

Relevance to unbalanced cables

For cables which use the shield as the return signal conductor, simply removing one of the signal conductors

and the associated source and load resistances from Figure 8 gives the equivalent circuit at 50/60Hz. The inductive and capacitive coupling between shield and centre conductor, and the voltage on the shield become DM additions to the signal (instead of CM), making their effects easier to calculate because the CM-DM conversion due to imbalances in the coupling coefficients of balanced conductors and the CMRR of the source and load circuits no longer need to be taken into account.

The inductive coupling of shield current into the signal conductor is approximately equal to the partial inductance of the cable, typically around 1 μ H per metre, and results in a series noise voltage in the signal that is not affected by source or load impedances unless they are less than 10 times the shield resistance. The capacitance between the shield voltage into the signal conductor is a figure usually found in the cable's data sheet, and creates a noise current in the signal circuit. The effect of this noise current on the signal's noise voltage increases as the parallel combination of the source and load impedances increase. The inductive noise lags the shield current by 90°, while the capacitively-coupled noise leads the shield-conductor voltage by 90°.

Most single-ended voltage-driven unbalanced signals in cables have a source impedance of $\leq 100\Omega$, so the capacitive coupling is insignificant compared with the inductive noise coupling, which in turn is insignificant when compared with the end-to-end shield voltage caused by shield current (remember, the shield is in the signal's return path, so series noise in the shield = series noise in the signal). A 30m long cable with 1A in the shield will suffer around 10mV of inductively coupled noise at 50Hz, but with a typical shield resistance of 0.5 Ω the voltage generated in the shield will be 0.5V.

It is easy to see, using this equivalent circuit, that balanced signalling techniques (sometimes called differential signalling) which do not use cable shields for signal returns have very significant noise benefits for low-level signals, or for analogue signals with a high signal/noise ratio. This is of course why these techniques have been used in pro-audio and data comm's (e.g. RS485) for decades. However, if it is not practical to redesign to use balanced signalling, paralleling the cable shield with the shields of a number of other cables, and/or with a PEC, will reduce the shield current and hence the noise because of real ground loop currents have a finite source impedance (see section 9 below).

9 Analysis of the effect of the building's ground system impedance

As was described in section 8, there is no significant DM noise caused by imbalanced inductive coupling between the ground loop current in a cable's shield and its signal conductors. However, the shield *voltage* generated by a current flowing in a shield's resistance does give rise to significant DM noise due to the imbalanced capacitive coupling between a cable's shield and its signal conductors. With typical good quality pro-audio equipment the DM noise from cable capacitive imbalance is often comparable with the DM noise caused by the finite CMRR of the equipment. Only the CM noise voltage on the interconnecting cables is relevant when trying to achieve good signal/noise ratios, shield currents don't matter.

It might be thought from the above that the DM noise resulting from bonding cable shields at both ends is about as bad as using shield termination at the source end. But although this would be correct for cables tested in a laboratory with a perfect voltage source (0 Ω impedance) generating the shield voltage – it is not a valid conclusion for real installations because they always have non-zero ground impedances.

A real pro-audio installation consists of many dozens, often hundreds, of shielded cables. If all of them had their shields bonded at both ends the resulting ground loop currents in each cable shield would be quite low and the low impedance of their paralleled shields (and PECs) would cause the ground potential differences between various locations to be considerably reduced. Since it is the CM voltage on the shields that dominates the creation of DM noise, reducing the ground potential differences by multiple 'shield-bonding-at-both-ends' and/or PECs as recommended by [4], [5], [6] and [7] will reduce the system's DM noise proportionally.

When sufficient shield bonding has taken place, and/or sufficiently low-resistance PECs employed, the DM noise generated by ground potential differences is negligible even for the highest quality audio systems. This is the great audio benefit of the 'shield-bonding-at-both-ends' technique, and it is discussed in more detail in this section.

When analysing the potential ground loop currents and ground potential voltages for a given installation a 'Thévenin equivalent circuit' can be assumed for the ground path between any two locations. This equivalent circuit could simply consist of a Thévenin voltage source for the potential difference between two physical locations, with a Thévenin source impedance in series with it. This is shown by Figure 10, which combines the equivalent circuit for the cable with that of the installation's protective bonding system (ground network)

to create an overall equivalent circuit which could be used to calculate real-life noise performance when bonding cable shields at both ends, and/or using PECs.

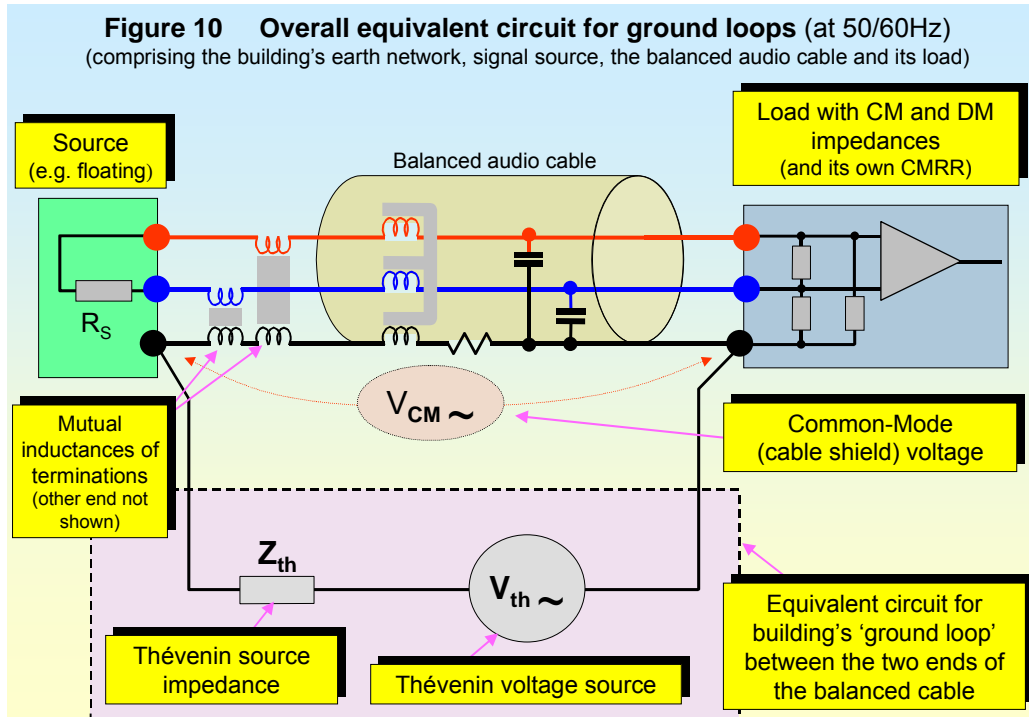

Because the ground voltage difference between the ends of a long cable in a building has a Thévenin source impedance, it is affected by the connection of the cable's shield at both ends and the shield's impedance. Reducing the impedance of the shield reduces the CM shield voltage while increasing the ground loop current flowing in the shield. Connecting a PEC in parallel with a shield also reduces the CM cable voltage, but in this case the PEC carries the increased ground loop current and the current in the cable shield is reduced.

Figures 11a-d show the relationship between an installation's ground source impedance and the CMRR of the cables tested as described above, both with and without PECs. The CMRRs of cables with shields that are not terminated at the load end show no change as ground impedance varies, but where shields are bonded at both ends and/or where PECs are used the overall CMRR achieved increases as the ground impedance increases and/or as the impedance of the shields and PEC decreases. An increasing cable CMRR really means that the Thévenin source voltage is decreasing in response to the lowered Thévenin impedance of the ground network caused by all the interlinked cable shields and PECs.

Typical pro-audio installations have numerous cables following any given route, so to help make Figures 11a-d more relevant to real installations we have included predicted CMRR figures for a bundle of 16 cables all shield-bonded at both ends plus a 25mm^2 copper cross-sectional area PEC (which would typically have an overall cable diameter around 13mm). A 25mm^2 copper PEC is representative of the impedance of many types of steel or other metal construction found in buildings that could also be used as PECs simply by bonding them to the equipment at both ends and running the audio cables along them (as described by [4]).

CMRR curves for '16 cables plus 25mm^2 PEC' are only plotted for cables B and G, assumed to be typical of adequate and very poor quality balanced audio cables respectively, and are a close approximation to the CMRR curves that could be drawn for 32 cables without a PEC. 100 cables with their shields terminated at both ends and no PEC would be better by about 10dB, for Thévenin source impedances of over 0.1Ω .

Figures 11a-d contain a great deal of data and we hope they are mostly self-explanatory. They show that the CMRR of cables bonded at both ends increases as the ground system's impedance increases, and that their CMRR also increases as the impedance of the cable shield(s) and/or PEC decreases.

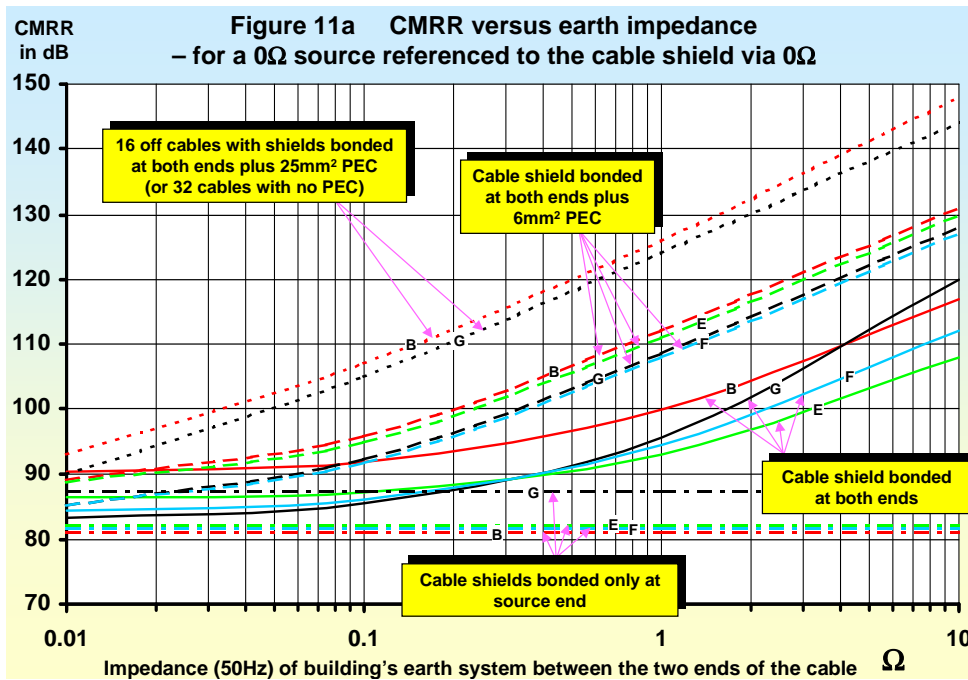

The '16 paralleled cables plus 25mm^2 PEC' curves in Figure 11a show that for a $100\text{m}\Omega$ Thévenin source impedance the CMRR is 25dB better than for shields unterminated at the load, and 20dB better than a single cable with its shield bonded at both ends. But when the source impedance is 1Ω , the improvement is about 43dB over 'shield unterminated at the load' and 25dB better than a single cable bonded at both ends.

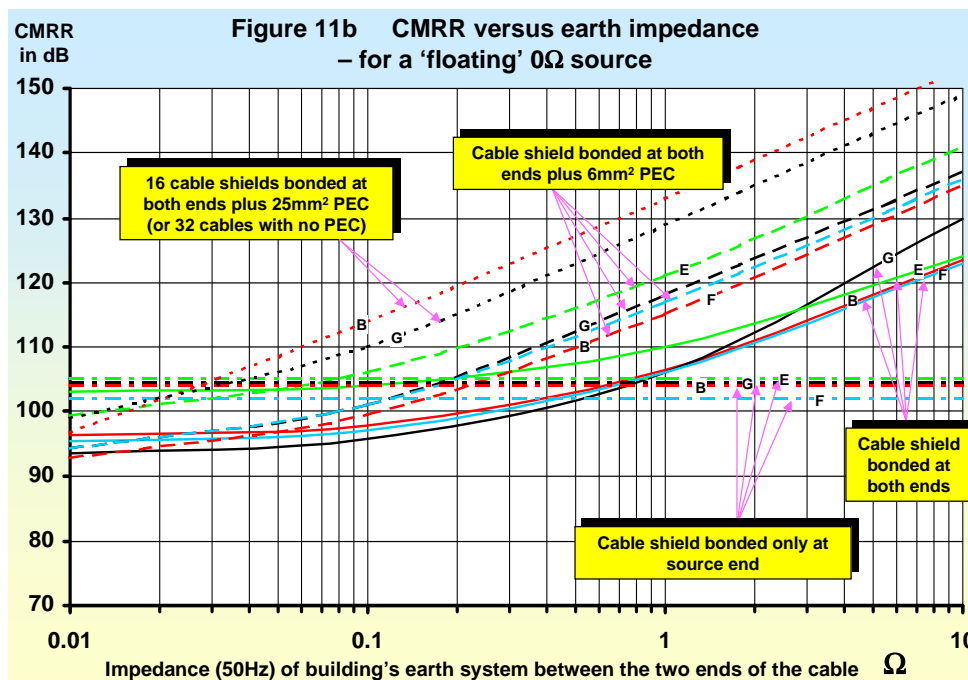

For cable G with a 200Ω floating load (the worst case for this intentionally badly balanced cable) Figure 11c shows that with a $100\text{m}\Omega$ source impedance 16 cables bonded at both ends plus a 25mm^2 PEC has a CMRR about 25dB better than a shield unterminated at the load, and for a 1Ω source impedance it is about 43dB better.

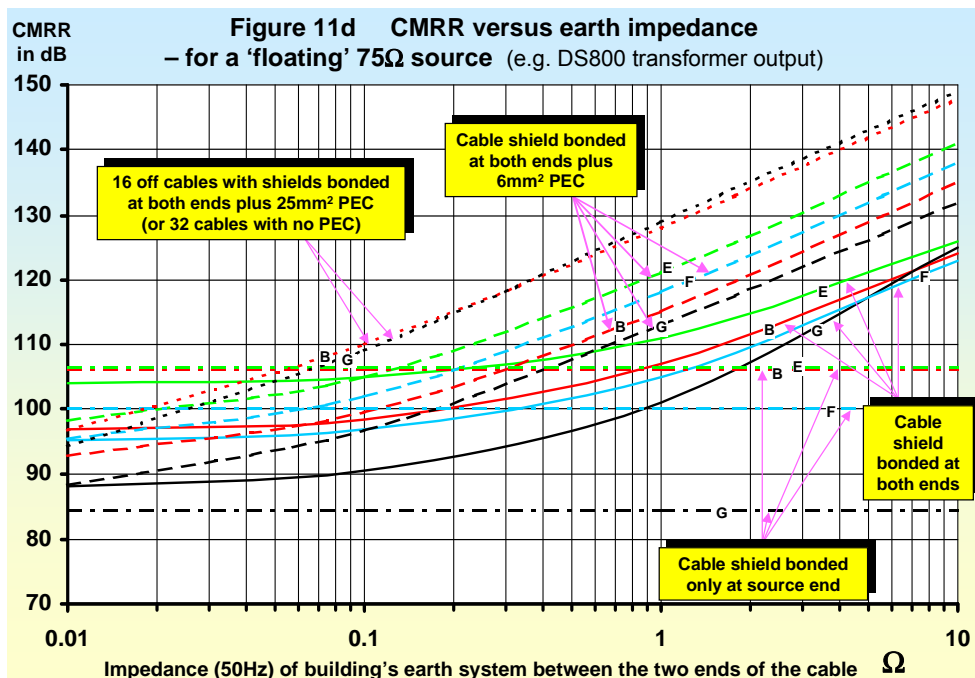
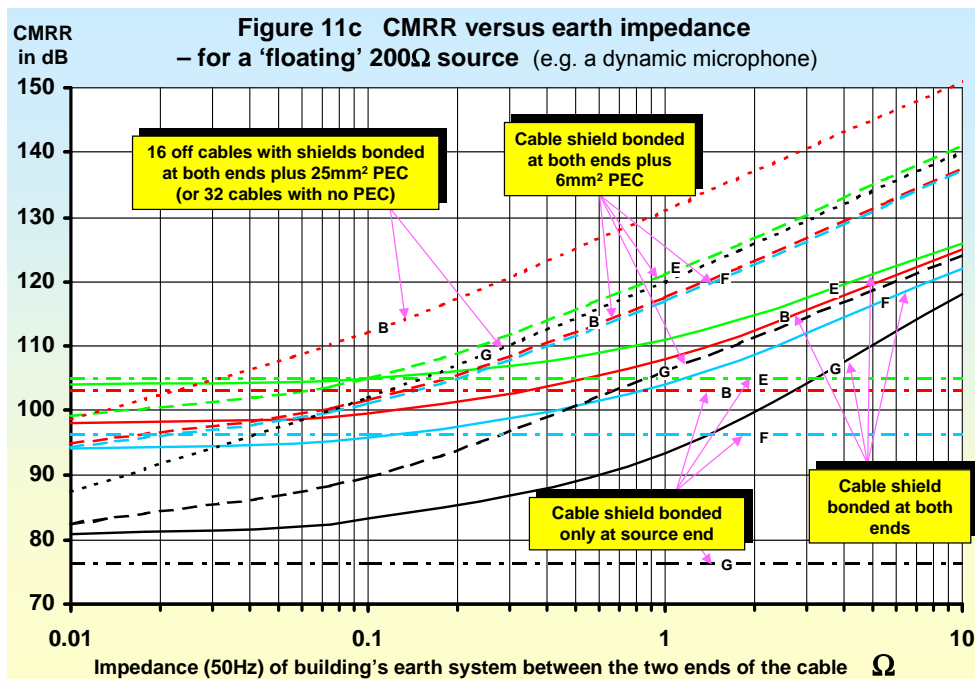

This discussion begs the question of what is the typical Thévenin source impedance and what is the typical Thévenin source voltage between the grounds at two locations in a pro-audio installation, at 50/60Hz. It seems to be difficult to find any published data on these parameters, but we can at least estimate their likely range of values.

In typical pro-audio touring rigs the shortest power cables are usually 25m long, with 50 or 100m being used in some situations (e.g. 100m lengths were used between the stage and the mixing desk or recording truck on the Rolling Stones' recent "Bridges to Babylon" tour). Touring rigs now often run the power and audio cables along the same routes, in which case the ground conductor in the power cables would act as a PEC for audio cables whose shields were bonded at both ends. The cross-sectional area of the ground conductors is usually 5mm² or 7mm², although 10mm² is sometimes seen where there are power amplification racks delivering many tens of kilowatts to the loudspeaker arrays.

Key for figures 11a - 11d	
	Cable B, shield bonded both ends
	Cable G (intentionally bad), shield bonded both ends
	Cable E, shield bonded both ends
	Cable F, shield bonded both ends
	Cable B, shield bonded both ends + 6mm ² PEC
	Cable G (intentionally bad), shield bonded both ends + 6mm ² PEC
	Cable E, shield bonded both ends + 6mm ² PEC
	Cable F, shield bonded both ends + 6mm ² PEC
	16 off cables type B, shields bonded both ends + 25mm ² PEC
	16 off cables type G, (intentionally bad), bonded both ends + 25mm ² PEC (Both the above roughly equivalent to 32 cables with no PEC)
	Cable B, shield bonded at load end only
	Cable G (intentionally bad), shield bonded at load end only
	Cable E, shield bonded at load end only
	Cable F, shield bonded at load end only

A great many legacy pro-audio installations exist in buildings. For example the UK's National Theatre has some power cable runs of around 250m length. In modern fixed pro-audio installations (and refurbishments to legacy installations) 5mm² or 7mm² conductors are typically used with radial power distribution, but most legacy installations seem to use smaller cross-sectional area power and ground cables, and some use ring distribution.

So the range of Thévenin source impedances likely between equipment sharing a common fused power feed seems to be from 44mΩ (a 10mm² conductor 25m long) to 630mΩ (a 5mm² conductor 250m long). But where an audio signal interconnects two items of equipment which are fed from separately-fused power feeds these should probably be doubled – to 88mΩ and 1.26Ω respectively.

But the only historical requirement for controlling the values of ground impedance is that they should be low enough to make sure that the fuse or breaker on a mains feed opens if there is a fault to ground anywhere along it. For a fuse or breaker to reliably open fairly quickly usually requires a current of three times its nominal rating. So in a 230V system a 30A rated power circuit needs a protective conductor impedance of under 1.27Ω (allowing another 1.27Ω in the power conductor), and for a 50A circuit this becomes 0.76Ω. In western Europe (at least) it seems fairly safe to assume that in most pro-audio installations the 50/60Hz Thévenin ground impedances between two items of equipment lie somewhere between 44mΩ and 2.5Ω.

Anecdotal evidence puts the Thévenin 50Hz source voltages at well under 1Vrms in pro-audio systems, typically 100mV rms or less. The argument that such low differences in ground potentials are typical in real installations was used by the pro-audio industry during the draft stages of [2], to justify reducing the test voltage used in the common-mode immunity test to -20dBu (77.5mV rms).

Many legacy installations in North America were not constructed with protective ground conductors in their power cables, and any ground conductors have usually only been added later when required by various items of equipment. It is anybody's guess what the Thévenin source impedance for the ground loop currents could be in such installations, but they could range from 44mΩ (where a heavy-duty ground conductor has been used) to several kΩ in the case of mains-powered equipment that requires a protective ground for safety reasons but has not been grounded.

Figures 11a-d show that the worst-case CMRR figures achieved by '16 cables bonded at both ends plus a 25mm² PEC' for Thévenin ground impedances of 0.1Ω and 2.5Ω with any of balanced sources (a-d) are 107dB and 135dB respectively – for the reasonably balanced cable type B. These are very good CMRR figures, especially considering that the equipment involved is assumed to have CMRRs around 80dB. For a total noise level of 5μV, usually regarded as negligible for most line-level audio signals, the worst-case CMRR of 107dB with a ground impedance of 100mΩ implies a Thévenin ground potential difference of 1.1Vrms at 50/60Hz, equivalent to a ground current of 11A. A worst-case CMRR of 135dB with a Thévenin source impedance of 2.5Ω implies a Thévenin source potential of 28V, again equivalent to a ground loop current of 11A. Such high ground loop currents imply an installation with very serious problems (e.g. 150μF

of leakage capacitance from 230V to protective ground, or 300 μ F in a 115V system) yet even so the audio performance will be excellent. Microphone level signals are discussed in section 10.

Turning to cable G, the worst-case CMRR figures for '16 cables bonded at both ends plus 25mm² PEC' for any of the sources (a-d) and Thévenin source impedances of 0.1 Ω and 2.5 Ω are 102dB and 128dB respectively. These are very good figures indeed for this most awful of balanced audio cables, and once again would be unlikely to result in noise levels of more than 5 μ V in almost any pro-audio installation. Cable G turns out not to be very much worse than cable B when installed in this manner, because it is only the CM noise *voltages* that contribute significantly to DM noise, and this installation technique reduces them dramatically.

It was mentioned earlier that when we were measuring the performance of cables with their shields bonded at both ends, many of our results were limited by the CMRR performance of our measuring instruments (around 80dB on average). The curves of Figures 11a-d are therefore representative of the overall CMRR of real installations using equipment with good CMRR performance. Improving the CMRR of the pro-audio equipment will probably achieve significantly lower DM noise with reasonable quality cables, as indicated by the 'additional tests' on cable F shown in Figures 7a-d.

Where audio systems use equipment with lower CMRRs than the measuring equipment used for these tests, bonding cable shields at both ends and/or using PECs will reduce the CM voltages on the cables and result in directly proportional noise reduction. Once again, the techniques recommended by [4] will allow the required audio noise performance to be achieved quickly and easily.

There are known instances, in many parts of the world, of potential differences of 70-90V between the metal chassis of items of equipment in some pro-audio/video installations. Where the protective bonding structure of the building is not faulty, such unsafe voltages are almost certainly caused by a protective bonding conductor not having been connected to a mains-powered equipment which needs one for safety reasons.

The practice of disconnecting the protective conductors from pro-audio equipment that should be grounded for safety reasons is widespread, despite the safety problems it can obviously cause. It is usually done during attempts to cure 50/60Hz hum problems when faced with a time or cost limit. The resulting ground loop currents are generally well under 100mA unless (or until) there is an insulation failure in the ungrounded equipment. Anyone who removes a protective grounding conductor from equipment that needs it for safety reasons could be subject to criminal penalties and/or civil lawsuits for liability if any death, injury, or damage (e.g. from fire) occurred as a result. Health and Safety inspectors in most countries usually have the power to immediately close down any facility where they found such practices being used, especially if they expose members of the public to risks.

Where such large differences in the ground potentials exist between different physical locations, steps should first be taken to discover the error and correct it. But – ignoring safety considerations for the moment – in such situations bonding all the affected cable shields to ground at both ends (and using a PEC for each cable bundle if necessary) is a perfectly reasonable solution for audio quality. Since the Thévenin source impedances of the ground currents are very high, probably several k Ω , even bonding the shield of a single cable at both ends would not cause a noise problem for its signals (as long as the equipment has been designed and assembled correctly – see section 11).

10 Some related issues

Choosing cable types when bonding shields at both ends

Low shield resistance is the most desirable characteristic. Braid shields with good optical coverage tend to have large amounts of metal in them, hence a lower resistance per unit length, and also tend to be the best for EMC reasons. Double-braid or braid and foil are even better for EMC, and will usually have even lower shield resistance.

Good capacitive balance (say 1% or less) is a desirable feature too, but will generally only make a significant difference if the CMRR of the equipment being connected is 90dB or more.

Microphone-level signals

A dynamic range of 120dB is usually the benchmark for high-quality professional audio systems. This implies that noise levels of up to 10 μ V may be quite acceptable for 'line level' pro-audio signals which can equal or exceed 10V full-scale levels. But microphone-level signals can be as small as 10mV full-scale, so achieving 120dB dynamic range can require noise levels as low as 10nV.

Microphones have their own 'Faraday cage' which protects them from low-frequency noise (and sometimes from RF interference). Bonding the shield of a microphone cable to the microphone's Faraday cage as well as to the equipment frame/chassis/enclosure at the load end (the microphone amplifier) allows us to create a fully shielded environment for the signal to maximise EMC performance. Since microphones are always 'floating' devices this end-to-end shield bonding means that no ground loop currents can flow in their cable shields, no CM voltages exist for their cables or amplifiers, and no CM-DM noise conversion can occur.

But microphone cabling in real installations can be much more complex than the above discussion implies, with 'microphone splitters' commonly being used to route microphone signals to a number of different items of equipment. Any ground potential differences between these items of equipment will cause CM voltages to arise on microphone cables which have their shields bonded at one end, and will also cause CM voltages to arise on cables which have their shields bonded at both ends (due to current flow in their shields' resistances). Assuming ground potential differences of 100mV at 50/60Hz means that our microphone interconnections (cables + equipment) need to achieve CMRRs of at least 140dB for a dynamic range of 120dB and a full-scale signal of 10mV. This can be very tricky, whatever shield bonding regime is followed.

Splitters that employ good quality isolating devices are always recommended, and the best technical approach is to amplify the microphone signals to more reasonable levels before they are distributed. This could be done by one channel of a mixing desk, or by an active splitter such as the XTA Electronics DSA800 (www.xta.co.uk or www.g1ltd.com for the USA) simulated by source d) in the above tests. Amplifying low-level signals as physically close as possible to their sources is always the best technical solution, if not the lowest cost. Other techniques include –

- Locating the items of equipment that use the same microphone signals in the same area, and powering them from the same mains feed. Improving the ground bonding between the equipment, e.g. with a 'ground mesh' may also help.
- Reducing the impedance of the ground bonding between the interconnected equipment until the CM noise voltages on their microphone cables are sufficiently low. As before, this can use cable shields and/or PECs. Cables with low-resistance shields are preferred.
- Using pro-audio equipment with better CMRR. The CMRR figures given in Figures 7a-d and 11a-d assumed equipment CMRRs in the region of 80dB at 50/60Hz and most of the results for cables B, E and F were limited by that. Equipment with CMRRs of 100dB at 50/60Hz would generally achieve 10 - 20dB better than those in Figures 7a-d and 11a-d for the same types of cables.
- Using cable types with capacitive imbalance specifications of 1% or less – although this is only likely to be useful when the CMRR of the associated equipment exceeds 90dB.

We conclude that following the recommendations of [4] to achieve EMC-compliant equipment, systems, and installations need create no problems for microphone signals, and the authors' real-life pro-audio experience supports this view.

Phantom power

This is the name given to a remote powering system for microphones that uses pin 1 (the shield pin) of the XLR connectors to carry the return current for a 48V dc (usually) CM voltage applied to the two balanced signal conductors.

No noise problems are created at audio or RF frequencies when the shield of a cable carrying phantom power is bonded to the equipment chassis at both ends – as long as the phantom power supply's mains-isolated DC output is floating (not referenced to 0V or ground) except for a single-point connection from its 0V output terminal directly to the chassis, usually at the 'star point'.

The effect of frequencies >50/60Hz

The imbalance in the capacitance between the shield and the balanced conductors has been shown to be the prime culprit for CM-DM noise conversion in cables. Imbalanced mutual inductance in cable terminations is generally a lesser, but possibly significant cause of further CM-DM noise conversion. As frequency rises above 60Hz, both of these will have a proportionally greater influence.

For example: a frequency of 550Hz (the 11th harmonic of 50Hz mains, and an increasing problem because mains supplies are everywhere suffering increased waveform distortion) will have a CMRR which is approximately eleven times worse (20.8dB) than the cable's performance at 50Hz. Many mains-related

noises in audio equipment are ‘buzzes’ rather than hums, indicating a high level of harmonic content. Following the recommendations of [4] will provide performance benefits similar to those it brings at 50/60Hz.

The minimal effect of inductive impedance at 50/60Hz

The above discussions and Figures 11a-d employed purely resistive impedances, a realistic assumption at 50/60Hz because the effects of inductance in the current paths is so low at these frequencies. For example, a 30m square loop of 6mm diameter ground conductor (which has a cross-sectional copper area of 16mm² and a typical continuous current rating of approximately 135A) has an inductance of approximately 200µH and an inductive reactance of 63mΩ at 50Hz. This compares with a resistance of 99mΩ and an overall reactive impedance $\{\sqrt{R^2 + X^2}\}$ of 117mΩ for three sides of the loop. A 30m square loop is a very roundabout ground path indeed, and a 16mm² conductor has a lower resistance than most ground conductors, so in most cases the inductive contributions to impedances will be insignificant at 50/60Hz.

11 Poor equipment design is the real cause of ‘ground loop’ noise

Employing the recommendations in [4] and encouraging ground loop currents to flow in the shields of balanced cables (and using PECs of appropriate cross-sectional area where required) appears to be a simple way to achieve EMC without compromising long-established pro-audio levels of noise and quality. This is especially true where exceptionally badly balanced cables of very low quality must be used.

Also, following [4] it makes it possible to design and install a pro-audio system that needs no ‘fiddling about’ with the cable shield terminations during commissioning to try to find a combination that actually achieves the desired low audio noise levels on all the signals.

So why is it that the technique of bonding the shields of balanced cables at both ends has such a bad reputation in the pro-audio industry?

The reason for this bad reputation appears to the authors to be the very poor shield bonding practices still used in much pro-audio equipment, systems, and installations. An example of one traditional and still commonplace shield-bonding practice is shown in Figure 12.

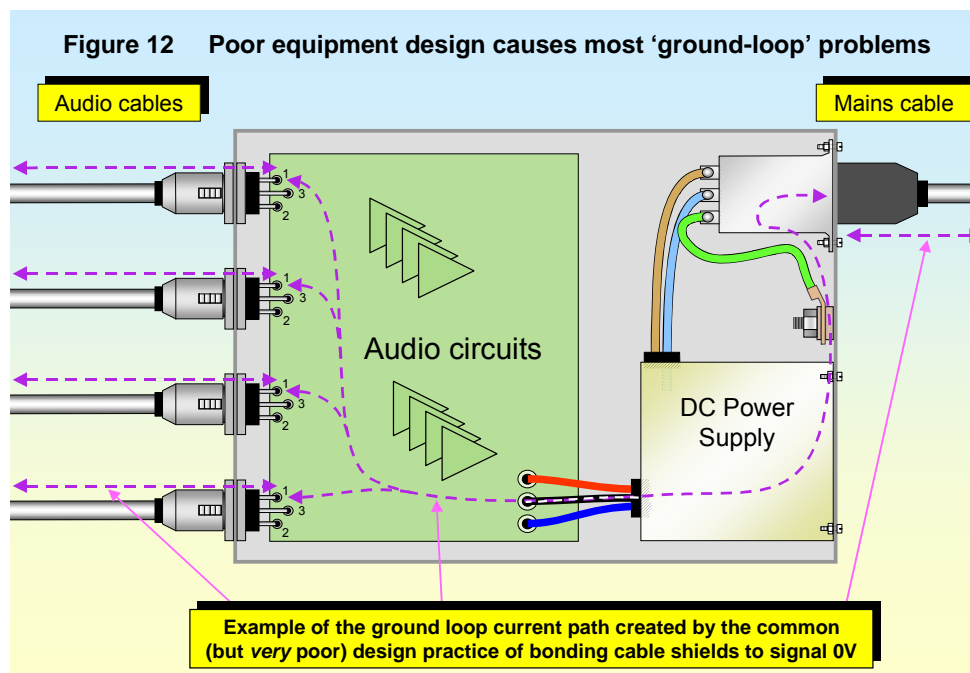

Figure 12 shows the commonplace pro-audio design practice of bonding cable shields to an input or output amplifier’s 0V reference. Ground loop routed from the outside world and flowing in the finite impedances of a sensitive audio circuit’s 0V system cause noise voltages to arise in circuits’ references, making their audio signals noisy. This problem is known in the EMC world as ‘common-impedance coupling’, and it would not happen if cable shield currents were connected directly to the chassis/frame/enclosure of the equipment, as is best for EMC.

An example: 12mm (½”) length of a 2.5mm (0.1”) wide PCB trace in ‘1oz copper’ has a resistance of 2.4mΩ. If this short trace carries shield (ground loop) currents the error voltage its resistance causes in the 0V would be 2.4mV per amp of shield current. 2.4mV is a very high noise level indeed (-50dBu in pro-audio terms), yet

the shared length of 0V trace in this example was a mere 12mm. A shared 0.1" wide 0V trace would need to be 0.05mm long for an error voltage of $10\mu\text{V}/\text{A}$, and much shorter for $10\text{nV}/\text{A}$. Don't forget that an error in a 0V path has exactly the same effect as the same error voltage in all the signals that use that 0V path for their return currents or reference voltages.

Another traditional pro-audio equipment design technique is to use a 'chassis' trace (or wire) to collect all the shield pin connections together and eventually connect them to the chassis. These 'chassis ground' traces are isolated from 0V but are almost always routed close to a number of parallel signal and 0V traces (or wires) and magnetically couple with them, giving rise to noise voltages. This problem is known as magnetic crosstalk (or stray mutual inductance coupling) and it would be practically eliminated if cable shields were connected directly to the chassis/frame/enclosure at the point where their cable enters the equipment, as is also best for EMC. Magnetic crosstalk can also occur from the ground currents flowing in the mains lead's protective ground conductor, so this should be short and routed well away from any signal conductors – better still bonded directly to the chassis/frame/enclosure without using any internal conductors – for example by correctly installing a metal-bodied mains EMI filter (see [5] and [6]).

Sometimes cable shields are connected to a circuit's 0V, but single-point grounding techniques are diligently applied to prevent common-impedance coupling. It has been shown above how difficult it is to achieve (say) $10\mu\text{V}$ per amp of shield current in such designs, but if we assume that this problem has been overcome we then find that the stray mutual inductance (magnetically-coupled crosstalk) between the branches of the 0V system, and between 0V branches and signal conductors, can be a very significant source of noise voltage injection.

One of the authors has made some measurements of the inductive coupling between a 100mm square loop and a long straight current-carrying conductor. Both were placed in the same plane (e.g. simulating crosstalk between conductors in a PCB) with the front edge of the square loop at various distances from the current-carrying conductor. The loop picked-up around $18\mu\text{V}$ per amp of 50Hz current in the long conductor when its front edge was at 9mm distance, $9\mu\text{V}/\text{A}$ at 21mm distance, and $6\mu\text{V}/\text{A}$ at 50mm. When a plate of 1mm thick steel was placed about 4mm away from the conductor and the loop, in parallel with their plane to simulate the base of an equipment under a PCB, the loop's coupled voltages approximately doubled for each of the spacings between the loop and the long conductor. Closer spacing, or a loop in the current-carrying conductor that overlapped part of the sensing loop, would have increased inductive coupling. Inductive coupling between ground loops and other conductors inside an item of sensitive equipment can clearly be very troublesome.

[7] and [8] both show that the problems caused in pro-audio equipment by not bonding cable shields direct to the chassis/frame/enclosure of equipment were well known to some as long ago as 1995.

12 Conclusions

We have shown that concerns about 50/60Hz noise generated by ground loops when bonding both ends of the shields of balanced audio cables are without basis. Ground loop currents are not a real problem for correctly-designed pro-audio equipment, in fact they are a real benefit.

Ground loop currents flowing in the shield of a balanced cable cannot give rise to significant DM noise due to inductive coupling between the shield and the signal conductors within a cable, because this mode of coupling only has a small effect and is intrinsically very well balanced. (With attention to the practical details of the shield-chassis connection at each end of the cable, no significant inductive coupling need occur there either.)

The only significant cause of DM noise in a balanced audio cable itself is the CM voltage between its shield and signal conductors acting upon its imbalanced shield-conductor capacitances. And this is comparable with the levels of DM noise caused when cable CM voltages are applied to typical high-quality pro-audio equipment.

As the number of cable shields bonded at both ends in an installation increases, and/or as more or lower-impedance PECs are used, the ground potential differences in an installation fall and so do the CM voltages on the cables. The large number of shielded cables available in a typical pro-audio installation make it is easy to reduce the ground potentials (equivalent to increasing the CMRR of the interconnections) so that the highest quality audio is predictably achieved at low cost. PECs can also be added to reduce ground potential differences.

Design, assembly and installation techniques that rely on bonding the shields of balanced cables at only one end, only achieve good noise performance for complex installations after lengthy commissioning with

unpredictable timescales and costs despite the level of skill that some people have developed with this technique. If RF capacitors are used to bond the shields to ground at their other ends to help achieve EMC compliance, material costs increase without shortened or more predictable commissioning times.

The authors' opinion is that it is most likely that any problems that have been observed when cable shields were bonded at both ends were caused by the bad equipment design practices described in section 11. Good design practices need cost no more than bad. They also make EMC compliance possible at low cost by utilising the RF shielding performance of cable shields (which is sacrificed by single-ended shield bonding techniques). Similar conclusions can be drawn for unbalanced signals and their cables.

Following [4], [5], [6] and [7] by bonding all cable shields at both ends (and using PECs if necessary) to help achieve compliance with the EMC Directive has been shown to enable pro-audio (and other) equipment, systems and installations to be designed, constructed, and installed with low costs – and with the lowest noise performance predictably achieved from the very first.

Even if EMC compliance was not necessary, bonding cable shields at both ends would still save large amounts of time and cost, and reduce project risks, compared with the traditional pro-audio methods.

13 References

- [1] EN 55103-1:1996 *Electromagnetic Compatibility, Product family standard for audio, video, audio-visual and entertainment lighting control apparatus for professional use, Part 1 – Emissions*. Mandatory for equipment under its scope when following the 'self-declaration to standards' route to EMC Directive compliance.
- [2] EN 55103-2:1996 *Electromagnetic Compatibility, Product family standard for audio, video, audio-visual and entertainment lighting control apparatus for professional use, Part 2 – Immunity*. Mandatory for equipment under its scope when following the 'self-declaration to standards' route to EMC Directive compliance.
- [4] IEC 61000-5-2:1997 *Electromagnetic compatibility (EMC) – Part 5: Installation and mitigation guidelines – Section 2: Grounding and cabling*
- [5] *EMC for Systems and Installations – Part 2*, EMC + Compliance Journal, April 2000, pp 8-17. Available on-line from the EMC + Compliance Journal's archives via www.compliance-club.com/KeithArmstrongPortfolio.htm
- [6] *EMC for Systems and Installations*, Tim Williams and Keith Armstrong, Newnes, 2000, ISBN 0 7506 4167 3, available from www.newnespress.com and from the EMC + Compliance Journal's book club (via www.compliance-club.com). Chapter 5 (*Grounding and bonding*) also describes the reason why star grounding is no longer a tenable method for almost any kind of installation, including pro-audio.
- [7] *Money for old cabling*, John Watkinson, Studio Sound, September 1996, pages 89-92
- [8] *EMC: who's really afraid now?* John Watkinson, Studio Sound, October 1995, page 13
- [9] Bonding the screens of cables at both ends, Keith Armstrong, ERA Conference: "Earthing 2000" 21-22 June 2000, Solihull (www.eratechnology.co.uk)

IEC standards are available from www.iec.ch/webstore. IEC and EN standards are available from National Standards Bodies (e.g. BSI, AFNOR, AENOR, DIN, etc.) in English and other EU official languages. To purchase IEC and EN standards in English in North America contact BSI's official agent: Mr. Dennis Allmon of CEEM, Inc., at 001-703-250-5900 or 001-800-745-5565 or by e-mail at dennis.allmon@ceem.com or solutions@ceem.com.

The authors:

Tony Waldron is Technical Manager for CADAC Electronics PLC. Sound Designer at The Royal Danish Theatre in Copenhagen (1979-81) and Head of Sound at The National Theatre, London (1983-89).
tony@cadac-sound.com www.cadac-sound.com

Keith Armstrong is Senior Consultant for Cherry Clough Consultants. In the late 1970s/early 1980s he designed very high-performance analogue circuits for Neve mixing desks.
keith.armstrong@cherryclough.com www.cherryclough.com